

TEKTRONIX®

**SW503
SWEEP
GENERATOR**

INSTRUCTION MANUAL

TABLE OF CONTENTS

Section 1	DESCRIPTION	Page
	1.1 INTRODUCTION	1-1
	1.2 ELECTRICAL CHARACTERISTICS	1-1
	1.3 ENVIRONMENTAL CHARACTERISTICS	1-2
Section 2	OPERATION	
	2.1 FRONT PANEL CONTROLS AND CONNECTORS	2-1
	2.2 OPERATING INSTRUCTIONS AND NOTES	2-4
	2.2.1 General Setup and First-Time Operation	2-4
	2.2.2 Cable Connections	2-5
	2.2.3 Impedance Matching	2-5
	2.2.4 Detecting (Demodulating)	2-5
	2.2.5 Sweep Rate Effects	2-6
	2.2.6 Overloading Effects	2-6
	2.2.7 Low-Level Measurements	2-6
	2.2.8 TV Receiver Interference	2-6
	2.2.9 Use with Digital Counter	2-6
	2.2.10 Operation with X-Y Plotters	2-6
	2.3 EXTERNAL CONTROL	2-7
	2.3.1 Frequency Control	2-7
	2.3.2 Amplitude Control	2-7
	2.3.3 Trigger Control	2-7
WARNING		
<i>The remainder of this table of contents refers to servicing instructions which should be performed by qualified personnel only.</i>		
Section 3	CALIBRATION	
	3.1 INTRODUCTION	3-1
	3.2 EQUIPMENT REQUIRED	3-1
	3.3 PRELIMINARY STEPS	3-2
	3.4 PROCEDURE	3-2
Section 4	CIRCUIT DESCRIPTION	
	4.1 GENERAL	4-1
	4.2 SWEEP RAMP GENERATOR	4-1
	4.2.1 Basic Operation	4-1
	4.2.2 Ramp Generator	4-2
	4.2.3 Single Sweep	4-2
	4.2.4 Line Rate	4-3
	4.2.5 CW Mode	4-3
	4.2.6 MANual Mode	4-3

TABLE OF CONTENTS (cont)

Section 4	CIRCUIT DESCRIPTION (cont)	Page
	4.3 SWEEP DRIVE CIRCUITRY	4-3
	4.3.1 Input Adder	4-3
	4.3.2 Ramp Shading Network	4-3
	4.3.3	
	4.3.3 Output Amplifier	4-5
	4.4 SWEEP OSCILLATOR MODULE	4-5
	4.5 RF OSCILLATOR MODULE	4-5
	4.6 HARMONIC MARKER MODULE	4-7
	4.7 MARKER AMPLIFIER	4-7
	4.8 COUNTER INTERFACE	4-9
Section 5	IMPLEMENTING SPECIAL FEATURES	
	5.1 CHANGING HORIZONTAL OUTPUT VOLTAGE	5-1
	5.2 INTERFACE THROUGH REAR CONNECTOR	5-1
	5.2.1 Introduction	5-1
	5.2.2 Mainframe Modification	5-1
	5.2.3 Vertical Output and Horizontal Output	5-1
	5.2.4 External Frequency Control or Modulation	5-2
	5.2.5 External Amplitude Control or Modulation	5-2
	5.2.6 External Trigger	5-2
	5.2.7 Digital Counter Interface	5-3
Section 6	REPLACEABLE ELECTRICAL PARTS	
OPTIONS		
Section 7	DIAGRAMS AND CIRCUIT BOARD ILLUSTRATIONS	
Section 8	REPLACEABLE MECHANICAL PARTS	
CHANGE INFORMATION		

LIST OF ILLUSTRATIONS

		Page
Figure 1-1	SW 503 RF Sweep Generator	Frontis
Figure 2-1	SW 503 Front Panel	2-2
Figure 2-2	Typical operating setup.	2-4
Figure 2-3	Typical resistive pads.	2-5
Figure 2-4	Basic detector schematic diagram.	2-5
Figure 2-5	Errors from sweep rate effects.	2-6
Figure 2-6	Markers selection switch location.	2-6
Figure 2-7	External control of frequency.	2-7
Figure 2-8	External control of amplitude.	2-7
Figure 3-1	SW 503 rear view.	3-2
Figure 3-2	SCOPE HORIZ waveform as seen on test oscilloscope.	3-2
Figure 3-3	SW 503 adjustment locations, left side.	3-3
Figure 3-4	SW 503 adjustment and test points locations, right side.	3-4
Figure 3-5	Normal interconnections for calibration.	3-4
Figure 4-1	SW 503 sweep ramp generator (simplified diagram).	4-2
Figure 4-2	Ramp shaping network.	4-4
Figure 4-3	RF sweep oscillator module block diagram.	4-5
Figure 4-4	Harmonic comb markers block diagram.	4-6
Figure 4-5	Counter interface signals sequence.	4-8
Figure 5-1	Rear plug-in connector P40 interface wiring.	5-2

LIST OF TABLES

Table 5-1	Digital Counter Interface Lines	5-3
-----------	---------------------------------	-----

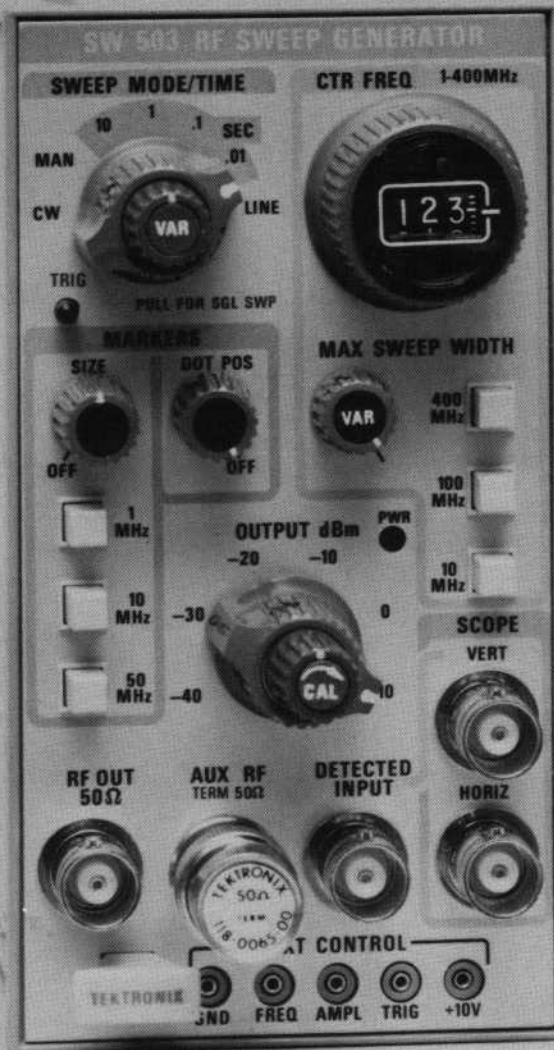

2051-1

Figure 1-1. SW 503 RF Sweep Generator.

DESCRIPTION

1.1 INTRODUCTION

The SW 503 is a TM 500-Series plug-in that provides a swept frequency of 1 MHz to 400 MHz with variable sweep rate, width, and output level. Crystal-controlled harmonic oscillators provide comb markers with 1 MHz, 10 MHz, or 50 MHz separation. When used with a DC 502 Option 7 Digital Counter, a frequency marker dot can be positioned anywhere within the frequency range of the SW 503 generator, and the frequency of the marker can be read directly on the counter. In the MANual sweep and CW modes, the continuous wave output of the generator can be read to the counter accuracy.

Access jacks on the front panel permit external signals to control or modulate the output amplitude and frequency, and to initiate a sweep.

The SW 503 has a 50 Ω output impedance; the SW 503 Option 1 has a 75 Ω output impedance.

1.2 ELECTRICAL CHARACTERISTICS

The following characteristics apply when the SW 503, in combination with a TM 500-Series power module, is operating within an ambient temperature of 0° C to +50° C, after a 30 minute or more warmup period.

NOTE

The instrument must be calibrated at an ambient temperature between +20° C and +30° C.

Center Frequency

Range: 1 MHz to 400 MHz or more.

Dial Accuracy: Within 8 MHz (readout accuracy can be increased by using the crystal markers or comb, or the dot marker when the SW 503 is used with a DC 502 Option 7 Digital Counter).

Drift: ≤ 100 kHz/5 minutes and ≤ 2 MHz/8 hours after a 30-minute warmup at a constant ambient temperature; a 5-minute stabilization period is required after the center frequency is changed.

Frequency Sweep

Maximum Width: Selectable; 400 MHz (+10% - 0%) 100 MHz ($\pm 15\%$), or 10 MHz ($\pm 15\%$).

Variable: Permits reducing sweep width from maximum down to approximately 200 kHz (when in 10 MHz maximum width position)

Display Linearity (VAR fully clockwise):

400 MHz position: 2%

100 MHz position: 3%

10 MHz position: 3%

Signal Purity

Residual FM: 10 kHz p-p or less in cw position.

Harmonic Related Spuri: Down 30 dB or more from 10 MHz to 400 MHz; 20 dB or more from 3 MHz to 10 MHz; and 15 dB or more from 1 MHz to 3 MHz.

Non-Harmonic Related Spuri: Down 40 dB or more from 1 MHz to 400 MHz fundamental frequency range.

Output Level

RF OUT: Maximum output is approximately 0.7 V rms. This corresponds to +10 dBm ± 0.5 dB into 50 Ω , or +57 dBmV ± 0.5 dB into 75 Ω (Option 1).

Output level can be attenuated 50 dB in 10 dB steps, and 20 dB by a variable attenuator. This provides a range from +10 dBm to -60 dBm for the SW 503, or +57 dBmV to -13 dBmV for SW 503 Option 1.

Step Attenuator Absolute Accuracy (with respect to zero attenuation): ± 0.2 dB/10 dB to a maximum of ± 1.0 dB.

Description—SW 503

CAL (variable attenuator): Continuously variable to 20 dB minimum.

Flatness: Within 0.5 dB peak-to-peak over the frequency range. Flatness is measured with the AUX RF output terminated into 50 Ω , at maximum output, and with detector (optional accessory), and includes harmonics.

AUX RF output: -2 dBm minimum into 50 Ω termination (same for Option 1).

BLANKING

Output is blanked during sweep retrace. Blanking is removed for manual and cw operation.

Frequency Markers (Harmonic Comb)

Crystal-controlled harmonic markers with 1 MHz, 10 MHz, or 50 MHz separation. Marker width is adjustable with the MAX SWEEP WIDTH VARIABLE control from about 400 kHz to 50 kHz and the marker amplitude is adjustable with the SIZE control from about 1 mV to 1 V peak-to-peak. If desired, an internal switch will remove the negative portion of the marker for use with an X-Y recorder. Marker size is about 0.5 V.

Marker Accuracy: 0.005% of marker selected.

Dot Marker

Functional only when DC 502 Option 7 Digital Counter is used with the SW 503. The dot marker can be adjusted over the frequency span of the display; accuracy of the dot frequency is relative to the display resolution and the counter accuracy. The sweep is interrupted at the dot position, a count is made, then the sweep continues.

Sweep Mode/Time

Modes: CW, manual, timed sweep, line triggered. When in one of the timed sweep speeds, the sweep is either free-running, or can be triggered by a front-panel button or an externally-applied pulse or switch closure.

Sweep Times: 10, 1, 0.1, and 0.01 seconds per sweep, $\pm 5\%$, in decade steps. Variable control slows each step by a factor of at least ten from its calibrated position.

Horizontal Output

From -250 mV to +250 mV (500 mV p-p $\pm 5\%$) with an output impedance of 1 k Ω . An internal resistor can be removed to change the output to approximately 10 V peak-to-peak with an impedance of 20 k Ω . (See Subsection 5.1 for instructions.)

External Frequency Control

The full frequency range can be controlled or modulated at rates to 4 kHz. Modulation sensitivity is approximately 50 MHz/volt. With reduced deviation and linearity, modulation rates to 100 kHz are possible. Input impedance is 10 k Ω .

External Amplitude Control

90% modulation can be obtained at modulation frequencies up to 25 kHz; the output level must be reduced 6 dB or more by the variable attenuation control. Sensitivity is about 1 V peak-to-peak per 10% of amplitude modulation. Input impedance is 10 k Ω .

1.3 ENVIRONMENTAL CHARACTERISTICS

Temperature Range:

Operating Range: 0°C to +50°C.

Non-Operating: -40°C to +75°C.

Ambient Temperature During Calibration: +20°C to +30°C.

Altitude Range:

Operating Range: To 15,000 feet.

Non-Operating: To 50,000 feet.

OPERATION

2.1 FRONT-PANEL CONTROLS AND CONNECTORS

Refer to Figure 2-1 for locations.

1 SWEEP MODE/TIME

This switch selects CW, MANual, a timed sweep, or LINE synchronized sweep.

CW position: The SW 503 produces a cw output whose frequency is dependent upon the CTR FREQ control setting (and EXT CONTROL, see 17).

MAN position: The SW 503 provides an output whose frequency is dependent upon the CTR FREQ setting, and the setting of the VAR control (also the settings of the MAX SWEEP WIDTH controls, see 8 and 9).

Timed sweep positions: The timed sweep positions are 10, 1, 0.1, and 0.01 seconds per sweep (when the VAR control is set to its fully clockwise position).

LINE position: In the LINE synchronized mode, the variable and single sweep controls have no effect.

2 VAR

When a timed position is selected, the VAR control can be used to slow the sweep by a factor of about ten from its calibrated setting. A timed sweep is recurrent but can be manually or externally triggered by pulling the VAR control out (see 3 and 17).

3 TRIG

This pushbutton triggers the sweep when the VAR control is pulled out (single sweep position) and the SWEEP TIME/MODE switch is in one of the timed sweep positions.

4 MARKERS

These pushbuttons select crystal-controlled harmonic (comb) markers with frequency spacings of 1 MHz, 10 MHz, or 50 MHz. The markers are applied to the SCOPE VERT connector and are mixed with the detected input from the device under test.

NOTE

An internal switch removes the negative-going portion of the markers, which is often desirable when using the SW 503 with an X-Y recorder. See Subsection 2.2.10.

5 MARKERS SIZE

This control varies the amplitude of the comb markers from about 1 mV to 1 V peak-to-peak.

6 DOT POSITION

When the SW 503 is used with a frequency counter with sweep stop logic such as the DC 502 Option 7, this control positions an intensified frequency marker dot anywhere on the display. The frequency of the dot position is then read out on the DC 502 with digital counter accuracy. See Subsection 2.2.9.

7 CTR FREQ (Center Frequency)

This multiturn control selects the center frequency of the RF OUT signal.

NOTE

It is necessary to correlate the setting of the CTR FREQ and MAX SWEEP WIDTH controls to avoid "wrapping around" zero frequency.

8 MAX SWEEP WIDTH

Three pushbuttons select maximum sweep widths of 10 MHz, 100 MHz, or 400 MHz.

9 VARIABLE (MAX SWEEP WIDTH)

The VARIABLE sweep width control reduces the width from the maximum selected sweep.

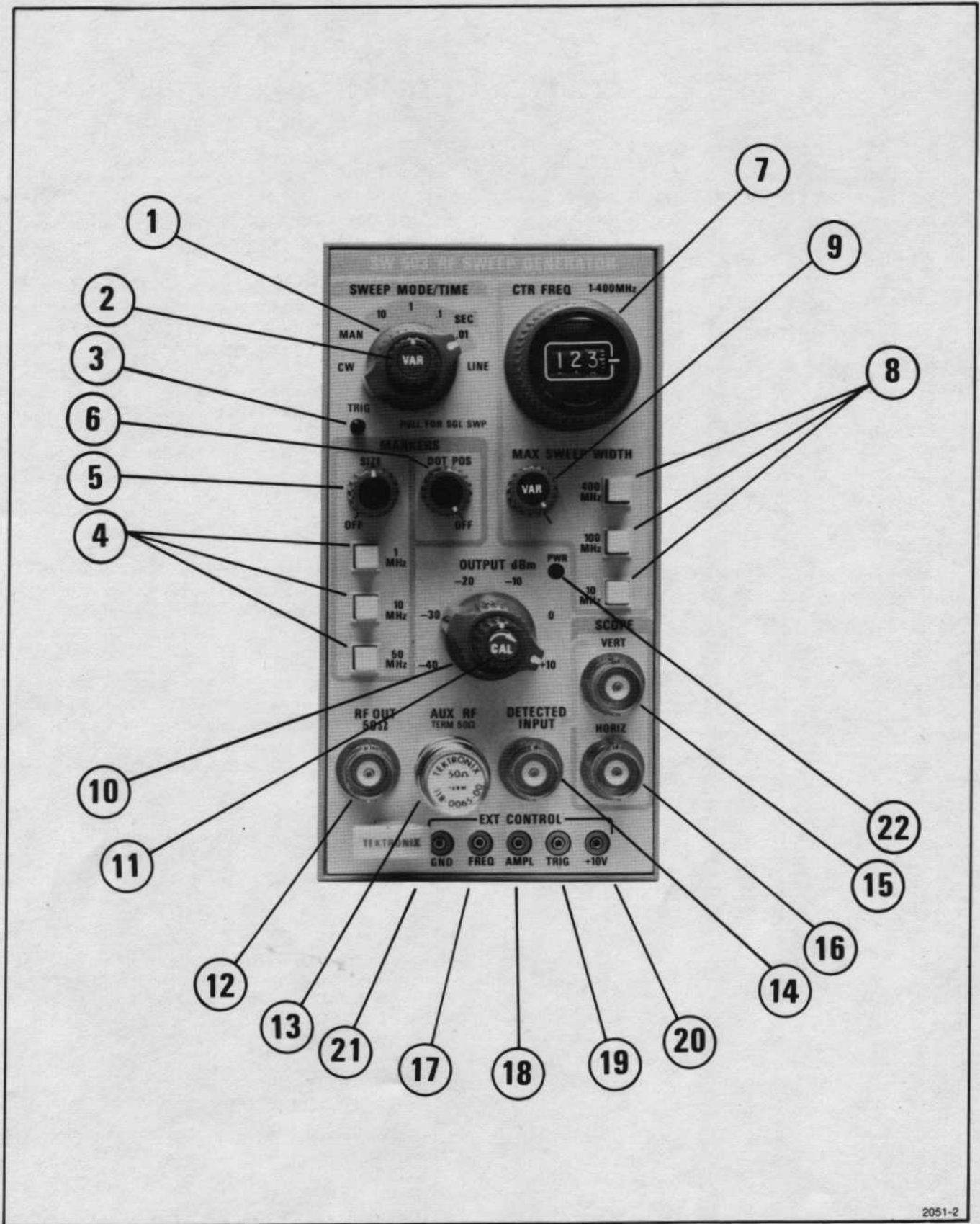

Figure 2-1. SW 503 front panel.

10 OUTPUT dBm (SW 503) or ATTENUATION dB (SW 503 Option 1)

SW 503: This six-step control selects the rf output in 10-dB steps from +10 dBm to -40 dBm.

SW 503 Option 1: This six-step control selects the rf attenuation in 10-dB steps from 0 dB to 50 dB. Maximum output levels are from +57 dBmV to +7 dBmV.

The output is calibrated as indicated when the CAL control (see 11) is in its fully clockwise position.

11 CAL (VARIABLE ATTENUATION)

The CAL control adjusts the RF OUT level to at least 20 dB below the level indicated by the step attenuator.

12 RF OUT

This connector provides a sweeping rf output signal, at a level selected by the attenuator controls. The source impedance is 50 Ω (SW 503) or 75 Ω (SW 503 Option 1).

13 AUX RF TERM 50 Ω

This connector provides a sweeping rf signal, for use with a frequency counter or other instrument. The output level is at least -2 dBm and is independent of attenuator settings. The source impedance is 50 Ω .

14 DETECTED INPUT

This connector allows returning the demodulated rf signal from the device under test (through an external detector if necessary) for the purpose of adding comb frequency markers.

15 SCOPE VERT

This connector is the output for the combined demodulated rf (from DETECTED INPUT) and comb frequency markers. The output is applied to the vertical input of an oscilloscope or display monitor.

16 SCOPE HORIZ

This connector is the output for the sweeping voltage that is provided for application to the horizontal input of an oscilloscope or display monitor. Nominal output amplitude is 500 mV p-p; an internal wiring change will provide 10 V p-p (See Subsection 5.1).

EXT CONTROL**17 FREQ**

This input allows an external signal to frequency modulate or control the output signal. Refer to Electrical Characteristics, Subsection 1.2, for signal requirements. Note that, when used with the SWEEP MODE/TIME switch in the MANual position, the external control is not dependent upon the settings of the MAX SWEEP WIDTH controls, whereas the manual sweep control is dependent.

18 AMPL

This input allows an external signal to amplitude modulate or control the output signal. Note that for maximum usefulness, the output amplitude must be reduced 6 dB or more by the VARIABLE attenuation control. Refer to Electrical Characteristics, Subsection 1.2, for signal requirements.

19 TRIG

When the VAR control is in the single sweep position (PULL for SINGLE SWEEP), this input allows an external signal to trigger the sweep. The applied signal can be a positive-going pulse of up to 10 V amplitude and at least 1 μ s duration, or can be supplied by a switch closure (solid state or mechanical) to the +10 V connector or similar source.

20 +10 V

This connector provides a convenient +10 V source to facilitate using the above-mentioned external controls.

21 GND (Ground)

This connector is connected to ground on the circuit board, to facilitate using the above-mentioned external controls, or for other signal ground purposes. DO NOT use this connector for safety earth.

22 PWR (Power)

This indicator lamp shows when power is applied to the instrument.

Operation—SW 503

2.2 OPERATING INSTRUCTIONS AND NOTES

2.2.1 General Setup and First-Time Operation

Install the SW 503 in a TM 500-Series power supply, then apply power to the unit, and allow instruments to warm up.

Connect the SW 503 Sweep Generator, the device under test, and the oscilloscope as shown in Figure 2-2. Refer to the following sections for details and special considerations.

After completing the setup, adjust the SW 503 controls for the required center frequency, sweep width, and output amplitude. If desired, turn the markers on and adjust their amplitude. For first-time operation, set the controls as follows:

SWEEP MODE/TIME .01 s
 VAR fully clockwise

CTR FREQ 200 MHz
 MARKERS SIZE midrange
 MARKERS frequency 50 MHz
 MAX SWEEP WIDTH 400 MHz
 VAR (max sweep width) fully clockwise
 OUTPUT dBm (SW 503) or
 ATTENUATION dB
 (SW 503 Option 1) Maximum (fully clockwise)
 position
 CAL (output) fully clockwise

Connect the RF OUT through a detector to the DETECTED INPUT. Adjust the oscilloscope or display monitor vertical and horizontal sensitivities for an on-screen display. Vary each of the above controls and note its effect on the the display.

A full specification check for the SW 503 is included in the Calibration Procedure, Subsection 3.4. Refer, however, to the warning page preceding Section 3.

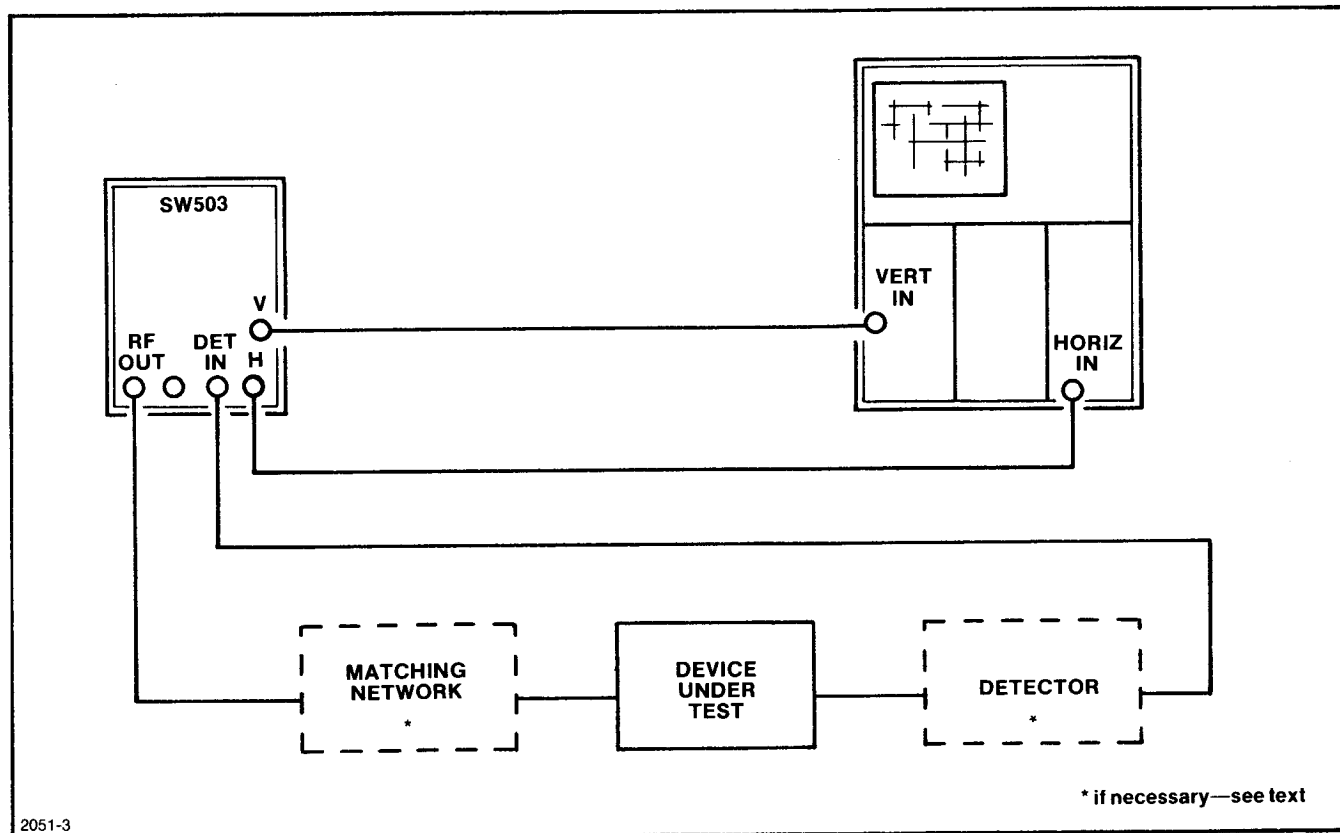

Figure 2-2. Typical operating setup.

2.2.2 Cable Connections

Since hum, rf leakage, spurious signal pickup, and standing waves must be kept to a minimum, it is essential that good connections be maintained throughout the entire setup. Use coaxial cables with bnc connectors wherever possible. The RF OUT cable especially should be kept as short as practical, and its impedance should match the output impedance of the SW 503. An idea of the integrity of the cabling can be obtained by connecting the detector, through the cables, directly to the rf output source, bypassing the device under test.

2.2.3 Impedance Matching

If the input impedance of the device under test is not the same as the sweep generator output impedance, a matching network should be used to ensure that a constant amplitude versus frequency is sent to the device under test. This matching network can be either resistive or inductive; the resistive matching pad is simpler to construct than the balun type transformer, but it provides more insertion loss. Figure 2-3 shows schematics for several resistive matching pads. Note that the leads connecting the 300 Ω output from the pad to the device under test should be as short as possible, preferably less than one inch.

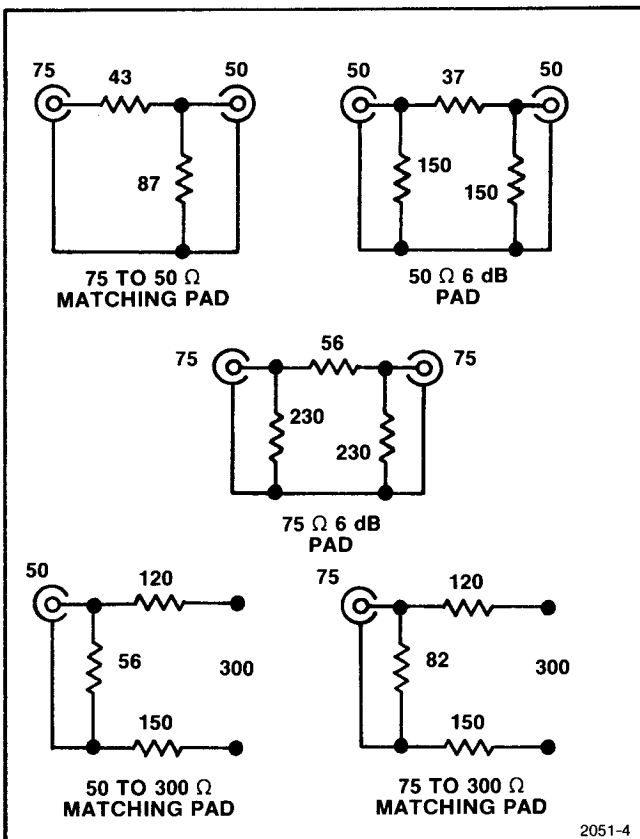

Figure 2-3. Typical resistive pads.

2.2.4 Detecting (Demodulating)

After the sweep generator signal passes through the rf circuit of the device under test, it must be demodulated before being connected to the DETECTED INPUT connector of the generator. If a demodulator is not a part of the device under test, one must be added externally. The input impedance of the demodulator must present the proper load to the device under test. Refer to Optional Accessories for recommended units, or see Figure 2-4 for the basic schematic of a detector.

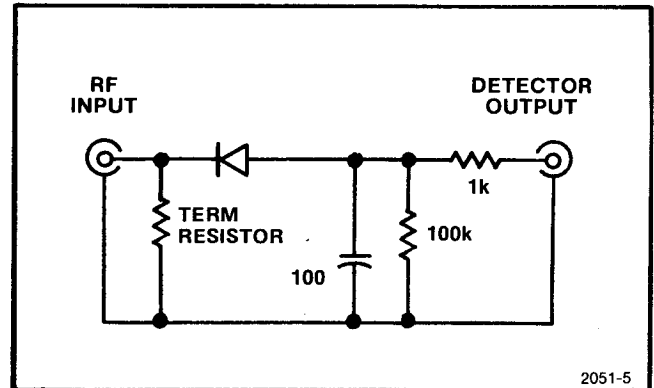

Figure 2-4. Basic detector schematic diagram.

2.2.5 Sweep Rate Effects

When sweeping rf circuits having rapid amplitude changes, errors may occur, due mainly to detector delays. Decreasing the detector output time constant will minimize this effect. Figure 2-5 illustrates sweep rate effect.

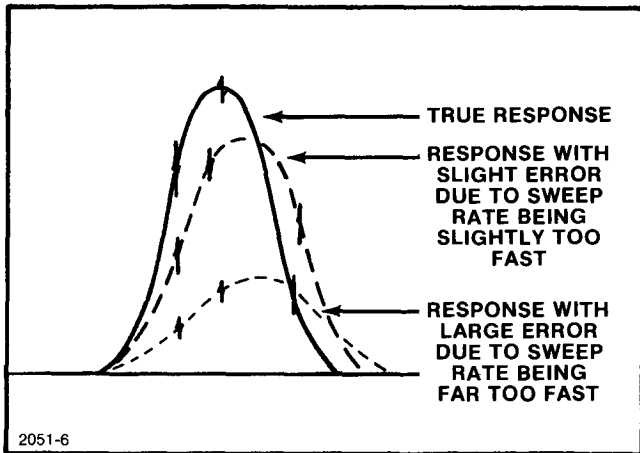

Figure 2-5. Errors from sweep rate effects.

To check for sweep rate effect, first set the sweep width to its lowest practical amount, then increase sweep time while closely observing the swept output response. Any change in the response indicates the sweep rate is too fast for a true response. When a further increase of sweep time does not change the response, a true response has been obtained.

2.2.6 Overloading Effects

The use of excessive input signals to the device under test can cause overloading. To assure that this condition is not present, and that the response is a true representation of the device under test, turn the OUTPUT dBm (ATTENUATION dB on SW 503 Option 1) and CAL controls to minimize output amplitude. Gradually increase the output amplitude until a response is obtained. Further increase of the output amplitude should not change the configuration of the response envelope except in amplitude. If the response envelope does change, such as flattening at the top, decrease the output just far enough to restore the proper configuration.

2.2.7 Low-Level Measurements

When making measurements at low levels, the effects of radiation and ground loops may become problems. Using double-shielded cables for rf signals helps minimize the radiation problem. Ground loops causing hum pickup can sometimes be eliminated by completing only one ground connection between each instrument. This applies particularly to the oscilloscope horizontal input. If the ground connection is made at the vertical input terminal, an additional ground at the horizontal input terminal will often result in hum pickup.

Measurement sensitivity will be determined by the type of detector used.

2.2.8 TV Receiver Interference

When using the SW 503 with a tv receiver, interference from the receiver's horizontal sweep circuit may appear on the response curve, making it difficult to observe a clearly-defined trace. Therefore, we recommend that the tv sweep circuit be disabled during testing.

2.2.9 Use With Digital Counter

The DOT POS control on the SW 503 functions only when a digital counter with sweep interrupt logic, such as the DC 502 Option 7, is used with the system. In use, the SW 503 sweep generating voltage is interrupted at the dot position (positionable with the DOT POS control), and the counter is told to initiate a count. At the conclusion of the counter gate time, the sweep is resumed. The counter provides an accurate indication of the SW 503 frequency at the dot location; the dot is actually caused by the sweep remaining stationary during the count.

In order for the DC 502 Option 7 to work properly, both units must be installed in specific compartments in a TM 500-Series power module equipped with Option 7. This option adds the wires necessary to interface the two units via their rear-panel connectors. See Subsection 5.2 for further information (also see warning page preceding Section 3).

2.2.10 Operation With X-Y Plotters

An internal switch (S510) in the SW 503 facilitates operation with X-Y plotters. This switch is located on the marker selection assembly directly behind the RF OUT connector (see Figure 2-6).

For normal operation, the switch is set toward the front panel. For plotter operation, with the switch set toward the rear of the instrument, the high-frequency marker signals are converted to a lower frequency (rectified) which is compatible with the operating speed of the plotter pen or stylus.

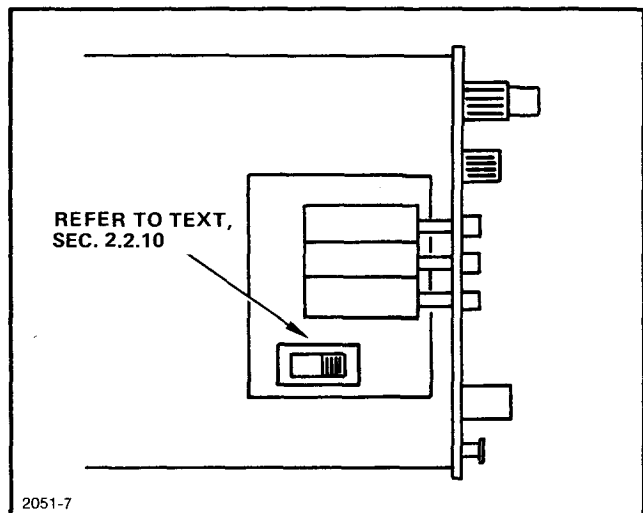

Figure 2-6. Markers selection switch location.

2.3 EXTERNAL CONTROL

Frequency, amplitude, and sweep initiation can be externally controlled through the use of the front panel mini-pin jack connectors. These features can be used singly or in any combination.

Functions of the front panel external control connectors can be duplicated through the rear plug-in connector by adding appropriate wires; instructions to do this are located in Subsection 5.2 (also see warning page preceding Section 3).

2.3.1 Frequency Control

External frequency control may be achieved by applying a voltage between 0 V and +10 V to the FREQ jack (refer to Electrical Characteristics, Subsection 1.2, for complete signal characteristics.). For example, connect a 10 kΩ potentiometer to the +10 V, GND, and FREQ jacks as shown in Figure 2-7.

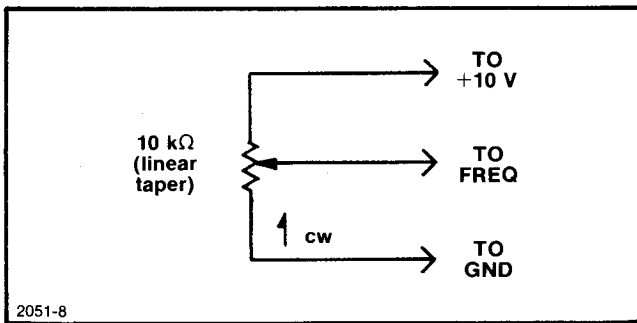

Figure 2-7. External control of frequency.

To frequency modulate the output, connect a source of suitable voltage range and adjustable amplitude between the GND and FREQ jacks.

Remote frequency adjustment or modulation is possible in any mode, although the most practical application is with the MANUAL or CW modes. The input to the FREQ jack is summed with the SWEEP WIDTH selection and the CTR FREQ selection (see Schematic Diagram); therefore, these settings interact.

NOTE

The greatest effect of a remotely-applied signal is realized when the SWEEP MODE/TIME switch is in the MANUAL position, the VAR (manual sweep) control is fully counterclockwise, the MAX SWEEP WIDTH is set to 400 MHz, its VAR control is fully clockwise, and the CTR FREQ is adjusted for 1 MHz.

2.3.2 Amplitude Control

External amplitude control may be achieved in a similar manner to frequency control (refer to Electrical Characteristics, Subsection 1.2, for complete signal characteristics). For example, to remotely adjust the amplitude, connect a 10 kΩ potentiometer to the +10 V, GND, and AMPL jacks as shown in Figure 2-8.

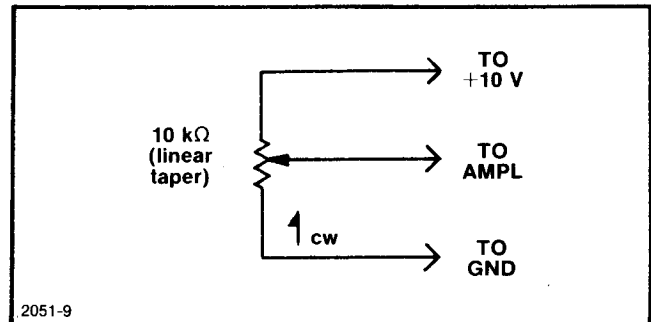

Figure 2-8. External control of amplitude.

To amplitude modulate the output, connect a source of suitable voltage range and adjustable amplitude between the GND and AMPL jacks.

The most practical application of external amplitude control is with the MANUAL or CW modes. When the CAL control is in its calibrated position (fully clockwise), applying +10 V will increase the amplitude approximately 5 dB, regardless of the step attenuator setting. When the CAL control is in its fully counterclockwise position (gain reduced about 20 dB), applying +10 V will increase the gain approximately 10 dB.

2.3.3 Trigger Control

When the SWEEP MODE/TIME switch is in the 10, 1, 0.1, or 0.01 s sweep modes and the VARIABLE control is pulled out for single sweep, a sweep may be initiated by applying a voltage of between about +2 V and +10 V to the TRIG jack. Two methods to accomplish this are:

- a) Making a switch closure between the TRIG and +10 V jacks;
- b) Applying a +10 V pulse between the TRIG and GND jacks. The pulse duration should be at least 1 μs.

The repetition rate of the applied signal must be slower than the sum of the sweep plus recovery times.

CALIBRATION

3.1 INTRODUCTION

To ensure maximum performance, the instrument should be checked after each 1000 hours of operation or every six months, whichever occurs first. It should also be checked whenever repairs have been made.

This section provides check and adjustment information for calibrating the instrument to its specification. We advise checking the performance, and recalibrating only those circuits that do not meet the specification.

In general, adjustments must be performed in the sequence given, and while the instrument is operating at an ambient temperature of +20°C to +30°C after a 30-minute warmup period.

3.2 EQUIPMENT REQUIRED

TYPE	MINIMUM PERFORMANCE REQUIREMENTS	EXAMPLES
Power Module		Tektronix TM 500-Series
Plug-in extender cable		Tektronix 067-0645-01
Display oscilloscope ¹	X-axis, 50 mV/div; Y-axis, 200 mV/div.	Tektronix SC 502
Test oscilloscope ¹	Vertical sensitivity, 0.1 V/div; sweep speeds 1 ms/div to 5 s/div. Triggered time base, 3% accuracy.	Tektronix 5000-Series
Detector (SW 503)	50Ω input; ±0.3 dB from 1 MHz to 400 MHz.	Tektronix 118-0070-00
Detector (SW 503 Option 1)	75 Ω input; ±0.3 dB from 1 MHz to 400 MHz.	Tektronix 118-0071-00
Power meter	-10 and +10 dBm ±0.5 dB.	Hewlett-Packard 435A
75 Ω to 50 Ω minimum loss pad (For Option 1 only.)		Tektronix 011-0112-00
Spectrum analyzer	1 MHz to 400 MHz coverage.	Tektronix 7L12 or 7L13
Digital voltmeter	0.1% dc voltage accuracy.	Tektronix DC 501 or DC 502

¹Although spoken of as separate instruments in the procedure, these may be the same instrument.

3.3 Preliminary Steps

WARNING

The following procedure exposes the technician to a maximum potential of about 67 V dc (± 33.5 V from ground). Take appropriate safety precautions. Refer also to Safety Notice page at the beginning of this section.

Remove the SW 503 Plug-In from the mainframe, remove its side covers, and reconnect it to the mainframe via the plug-in extender cable.

Turn the system power on and allow the units to warm up for 30 minutes or more.

3.4 PROCEDURE

1. Check/Adjust Power Supplies

a. Connect the digital voltmeter between ground and pin 2 of the Sweep Oscillator Module A20 (locate in Figure 3-1).

b. Adjust R310 (+18; locate in Figure 3-4) for a reading of +18.00 V.

c. Connect the digital voltmeter between ground and pin 3 of Sweep Oscillator Module A20 (locate in Figure 3-1), and check for a reading of -18.00 V ± 0.2 V.

d. Connect the digital voltmeter between ground and the front panel +10 V jack, and check for a reading of $+9.8$ V ± 0.2 V.

e. Connect the digital voltmeter between ground and pin 3 of Marker Module A10 (locate in Figure 3-1), and check for a reading of $+5$ V ± 0.2 V.

2. Adjust Sweep Generator

a. Set the SWEEP MODE/TIME control to 0.01 s, and the VAR control fully clockwise.

b. Connect the SW 503 SCOPE HORIZ to the test oscilloscope vertical input. Adjust the test oscilloscope vertical sensitivity to 0.1 V/div² and time base to 5 ms/div, and adjust triggering and positioning for a stable pattern similar to Figure 3-2.

c. Adjust R405 (FREQ) for a sweep time (positive-going portion of waveform) of 10 ms, as indicated in Figure 3-2. See Figure 3-3 for adjustment location.

²SW 503 sweep voltage output (SCOPE HORIZ) is normally 500 mV p-p; however, instruments have provision for changing the sweep voltage to 10 V p-p (see Subsection 5.1).

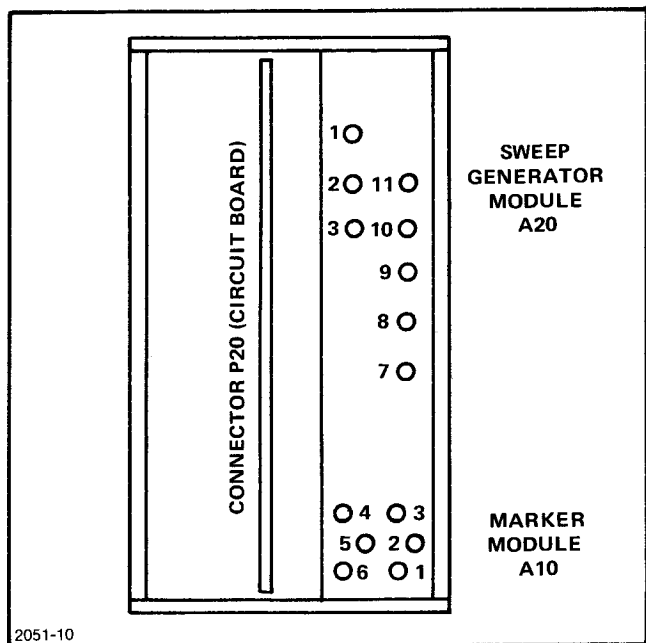

Figure 3-1. SW 503 rear view.

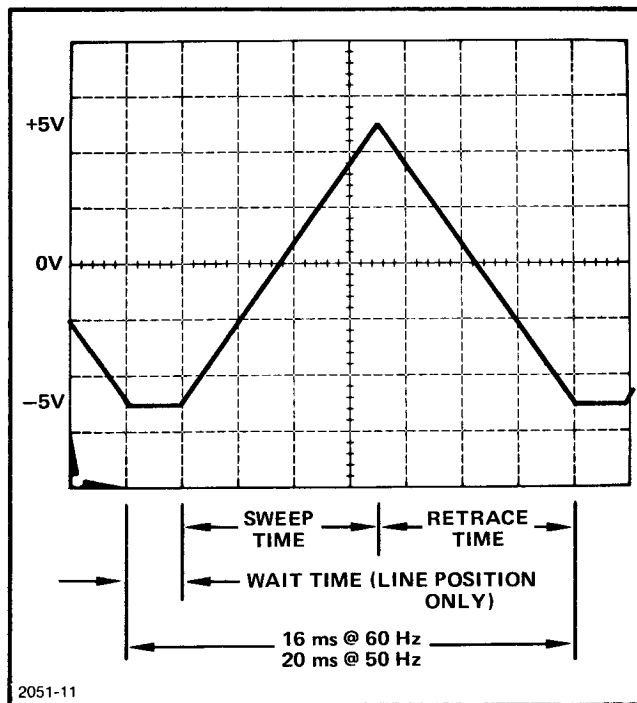

Figure 3-2. SCOPE HORIZ waveform as seen on test oscilloscope.

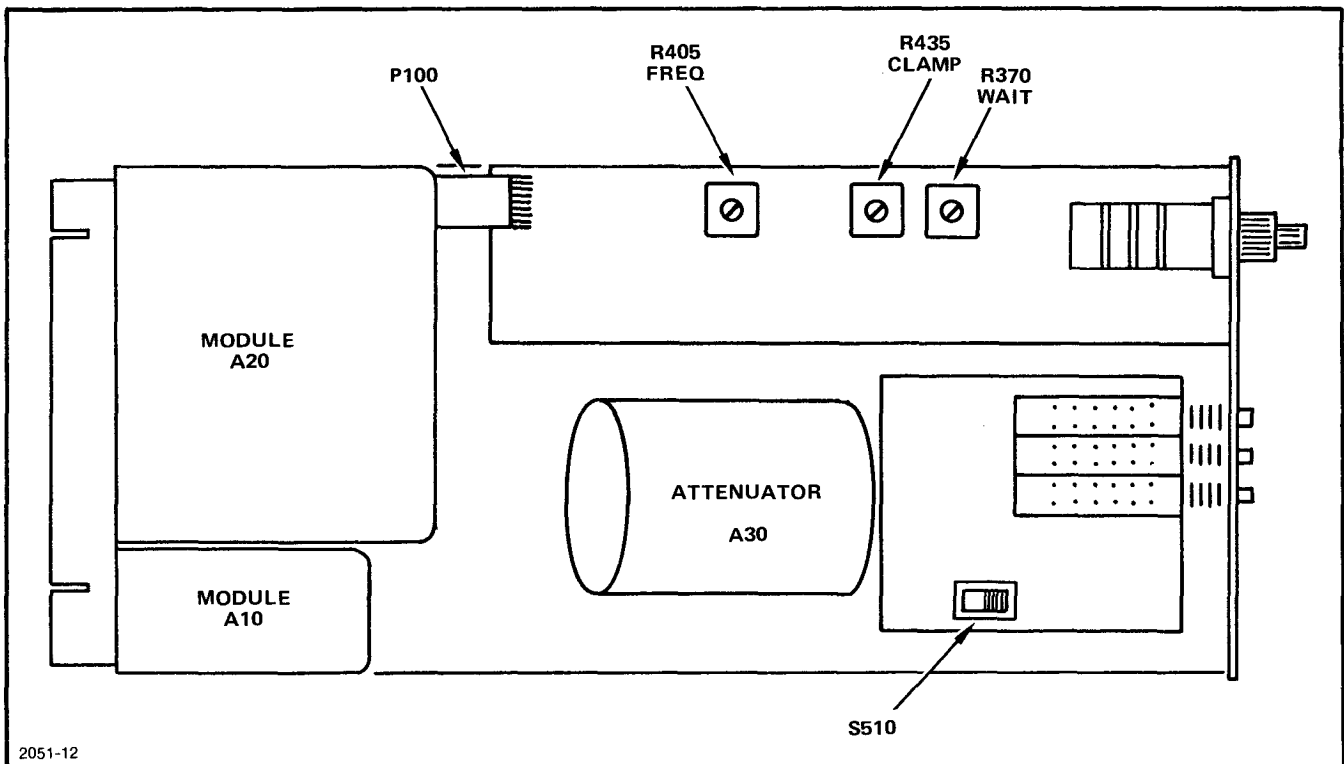

Figure 3-3. SW 503 adjustment locations, left side.

d. Rotate the VAR control fully counterclockwise. The sweep time should be 100 ms or greater (reduce test oscilloscope sweep time as necessary to check).

e. Return the VAR control to its fully-clockwise position, and set the SWEEP MODE/TIME switch to LINE. Set the test oscilloscope time base to 1 ms/div, and adjust R435 (CLAMP) to clamp the base of the waveform to the same amplitude as the waveform base in step c (Figure 3-2). See Figure 3-3 for adjustment location.

f. Adjust R370 (WAIT) for a wait time of approximately 1 ms as indicated in Figure 3-2. See Figure 3-3 for adjustment location.

3. Adjust Frequency Calibration

a. Set the SWEEP MODE/TIME switch to CW, and the CTR FREQ control to 200 MHz.

b. Connect the digital voltmeter between ground and U210A pin 1 (locate in Figure 3-4).

c. Adjust R185 (BAL) for a voltage of zero on the digital voltmeter. See Figure 3-4 for adjustment location.

d. Connect the SW 503 to the display oscilloscope as indicated in Figure 3-5, and set the controls as follows:

SW503

SWEEP MODE/TIME	0.01 s
(Sweep Time) VAR	Fully clockwise
CTR FREQ	200 MHz
MAX SWEEP WIDTH	400 MHz
VAR (Max sweep width)	Fully clockwise
50 MHz MARKERS	ON (pushed in)
MARKER SIZE	Midrange
OUTPUT dBm (50 Ω units)	+10
ATTENUATION dB (75 Ω units)	0
CAL (output dBm)	Fully clockwise

Display Oscilloscope

Mode	X-Y
Horizontal sensitivity	50 mV/div ²
Vertical sensitivity	200 mV/div

²SW 503 sweep voltage output (SCOPE HORIZ) is normally 500 mV p-p; however, instruments have provision for changing the sweep voltage to 10 V p-p (see Subsection 5.1).

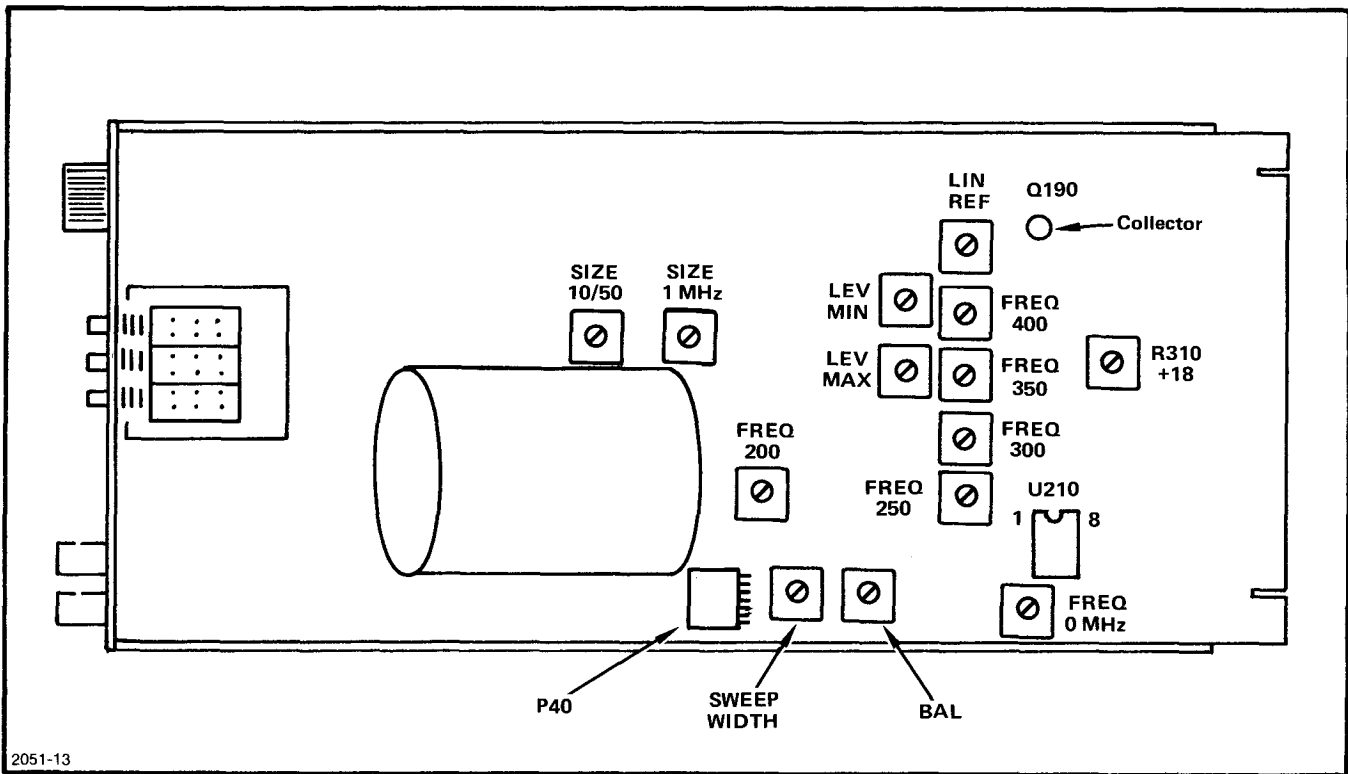

Figure 3-4. SW 503 adjustment and test points locations, right side.

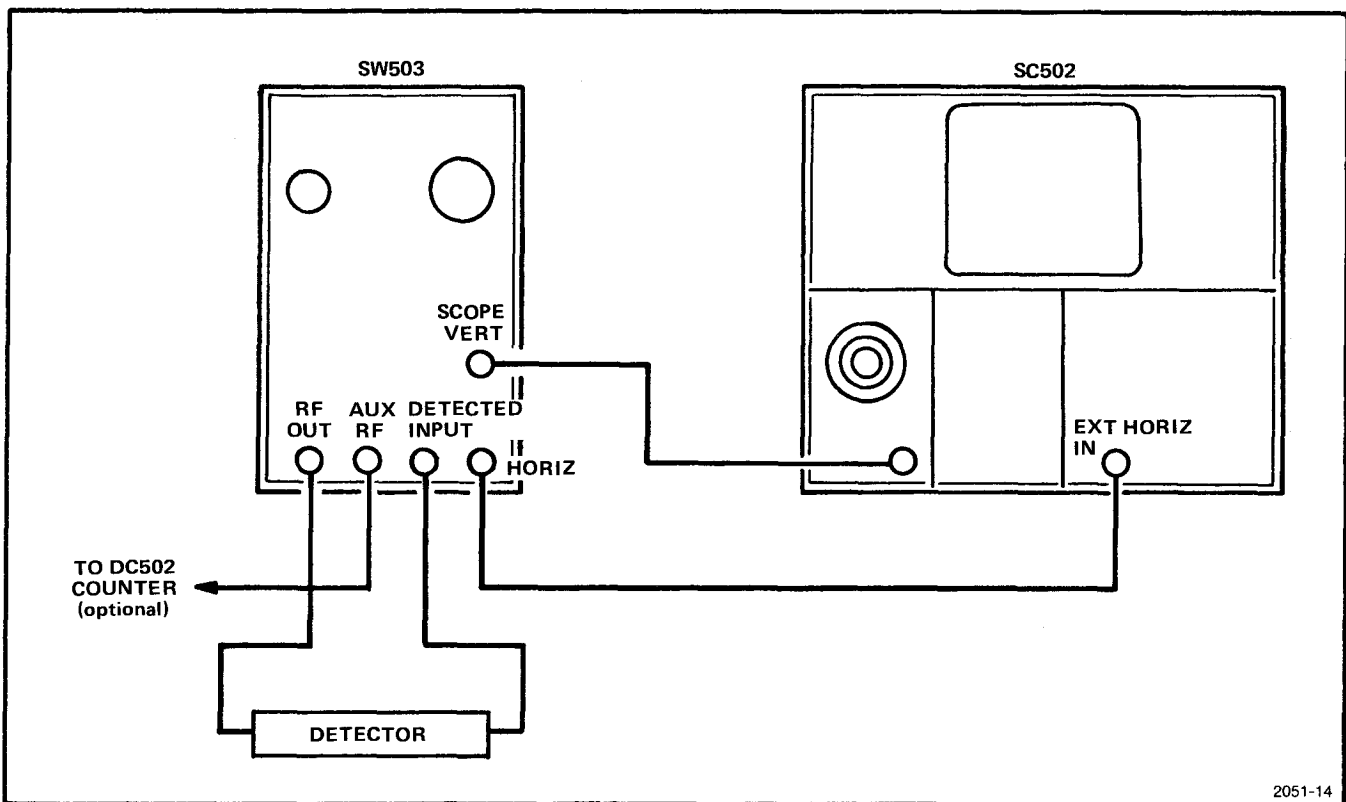

Figure 3-5. Normal interconnections for calibration.

To identify the frequencies shown on the resultant display, the markers must be positively identified. The zero beat in the swept rf output does not vary in amplitude with the MARKERS SIZE control and looks distinctly different than a marker; therefore, it can be used as a frequency reference. The first marker to the right of zero is 50 MHz, the second marker is 100 MHz, and so on. The frequency of each marker can be identified by referring to the zero beat until the CTR FREQ dial reading is sufficiently calibrated.

e. Identify the 200 MHz marker, then reduce the frequency sweep with the MAX SWEEP WIDTH VAR control and adjust R235 (FREQ 200) to place the marker in the center of the oscilloscope display. See Figure 3-4 for adjustment location.

f. Set the CTR FREQ control to 50 MHz and adjust R225 (FREQ 0 MHz) to place the 50 MHz marker at the center of the oscilloscope display. See Figure 3-4 for adjustment location.

g. Reset the CTR FREQ to 200 MHz, and repeat steps e and f until the interaction is minimized.

h. Set the CTR FREQ control to 350 MHz and connect a probe from the test oscilloscope to the junction of Q190 collector and CR196 cathode (locate in Figure 3-4). Adjust the test oscilloscope to display at least one cycle (2 ms/div), and adjust its vertical sensitivity for a full-screen display, dc-coupled (>2 V/div).

i. Momentarily disconnect the probe, or switch the test oscilloscope input to ground, and vertically position the trace to center screen; then reconnect the probe and adjust R195 (LIN REF) to center the displayed waveform voltage to about zero. See Figure 3-4 for adjustment location.

j. Set the CTR FREQ control to 250 MHz, and adjust R215 (FREQ 250) to place the marker at the center of the display. See Figure 3-4 for adjustment location.

k. Set the CTR FREQ to 300 MHz, 350 MHz, and 400 MHz respectively, and adjust the corresponding frequency adjustments (R210, R204, and R201) to place the correct marker at the center of the display. See Figure 3-4 for adjustment locations.

l. Set the CTR FREQ control to 200 MHz, and MAX SWEEP WIDTH controls for 400 MHz (VAR fully clockwise).

m. Adjust R180 (SWEEP WIDTH) so that both the 0 Hz and the 400 MHz markers are just visible at the ends of the sweep. See Figure 3-4 for adjustment location.

4. Check Sweep Width

a. Press the 100 MHz MAX SWEEP WIDTH and 50 MHz MARKERS buttons, and check that the sweep width is at least 100 MHz. (That is, three markers visible. It may be necessary to vary the CTR FREQ slightly.)

b. Press the 10 MHz MAX SWEEP WIDTH and 10 MHz MARKERS buttons, move the CTR FREQ about 5 MHz as necessary, and check that the sweep is at least 10 MHz (that is, two markers visible).

5. Check Frequency Dial Accuracy

a. Press the 400 MHz MAX SWEEP WIDTH and 50 MHz MARKERS buttons.

b. Adjust the CTR FREQ control from 50 MHz to 400 MHz and check that it reads within ± 8 MHz of a multiple of 50 MHz when each marker is centered.

6. Adjust Output Level

a. Adjust the front panel controls as follows:

CTR FREQ	100 MHz
SWEEP MODE/TIME	CW
OUTPUT dBm (50 Ω)	+10 dBm
or ATTENUATION dB (75 Ω)	0 dB
CAL (output dBm)	Fully clockwise

NOTE

For standard instruments with 50 Ω output, perform steps b through e. For Option 1 instruments with 75 Ω output, perform steps f through i.

b. Connect a power meter to the RF OUT connector.

c. Adjust R240 (LEVEL MAX) for an output level of +10 dBm. See Figure 3-4 for adjustment location.

d. Set the CAL control fully counterclockwise, and adjust R245 (LEVEL MIN) for an output level of -10 dBm. See Figure 3-4 for adjustment location.

e. Rotate the CAL control fully clockwise, and repeat steps c and d to minimize interaction.

Calibration—SW 503

f. Connect a power meter (with 50 Ω input) through a 50 Ω to 75 Ω minimum loss attenuator (Tektronix Part Number 011-0112-00) to the RF OUT connector.

g. Adjust R240 (LEVEL MAX) for a power meter indication of +2.5 dBm.

h. Set the CAL control fully counterclockwise, and adjust R245 (LEVEL MIN) for a power meter indication of -17.5 dBm.

i. Rotate the CAL control fully clockwise, and repeat steps g and h to minimize interaction.

7. Check Attenuator Steps

NOTE

There are several ways the attenuator step accuracy could be checked. Steps a through c below outline one method; steps d through e give an alternate method.

a. Set the CAL control fully clockwise and note the power meter reading.

b. Reduce the OUTPUT dBm or ATTENUATION dB control one step and check for a 10 dB reduction on the power meter indication (within ± 0.2 dB per 10 dB steps, maximum of ± 1.0 dB overall).

c. Reset the power meter range as necessary and repeat step b for all attenuator steps. Preferably check both steps of the output attenuator on the same range of the power meter to avoid compounding tolerances.

d. (Alternate Method) Connect the RF OUT through a suitable rf step attenuator or attenuator pads to a detector (which is connected to the DETECTED INPUT).

e. Compare the difference in the output when attenuated by the internal attenuator, to that when attenuated by the external precision attenuator. The difference between the two outputs is the attenuator error. Maximum allowable error is 2%, not including the basic flatness or vernier attenuator error. The detector can be used at levels down to about -40 dBm; at lower levels an rf amplifier or spectrum analyzer must be used.

8. Check Flatness

a. Connect the RF OUT through a detector (optional accessory) to the DETECTED INPUT and set the controls as follows:

SWEEP MODE/TIME	0.01 s
CTR FREQ	1 MHz
MAX SWEEP WIDTH	10 MHz
OUTPUT dBm or ATTENUATION dB	Maximum output
CAL (Output dBm)	Fully clockwise
Display oscilloscope vertical input	50 mV/div, dc-coupled

b. Adjust the display oscilloscope vertical sensitivity for a 10-division display. To accomplish this, since most displays have only eight divisions vertically, first adjust for eight divisions using the display oscilloscope variable attenuator control, then reposition the display (not the baseline) two divisions toward the center, and readjust the variable attenuator for two more divisions amplitude.

c. Adjust the CTR FREQ throughout its range and check that the vertical display remains within 0.6 major division. With the vertical amplitude set as previously shown, this corresponds to 0.5 dB.

9. Check AUX RF Output Level

a. Terminate the RF OUT, connect a power meter to the AUX RF connector, and switch the SWEEP MODE/TIME to CW.

b. Tune the CTR FREQ throughout its range, and check that the AUX RF level is at least -2 dBm.

10. Check Harmonics and Spurious Signals

a. Connect the SW 503 RF OUT to the input of a spectrum analyzer, such as a 7L12 or 7L13.

b. Set the SWEEP TIME/MODE to CW, CTR FREQ to 1 MHz, and output to maximum.

c. Adjust the spectrum analyzer to display the 1 MHz fundamental, with a Span/Div of 100 MHz. Set the Reference Level as low as possible without overdriving, and position the top of the fundamental to a convenient reference line.

d. Vary the CTR FREQ control throughout its range, adjust the spectrum analyzer as necessary, and check that the SW 503 harmonics are at least 15 dB below the fundamental from 1 to 3 MHz, at least 25 dB below from 3 to 10 MHz, and at least 30 dB below from 10 to 400 MHz. Also check that the non-harmonic spurious signals are at least 40 dB below the fundamental.

11. Adjust Markers Size

a. With the SW 503 connected to the display oscilloscope as in Figure 3-5, set the controls as follows:

SWEEP MODE/TIME	0.01 s
CTR FREQ	200 MHz
MAX SWEEP WIDTH	10 MHz
OUTPUT dBm (50 Ω)	0 dBm
or ATTENUATION dB (75 Ω)	10 dB
MARKERS	50 MHz

b. Center the marker, then adjust the MAX SWEEP WIDTH VAR control until the marker is about one division wide.

c. Adjust the display oscilloscope vertical sensitivity to about 50 mV/div, then adjust the MARKERS SIZE control for a nearly full screen amplitude.

d. Push the 1 MHz MARKERS button and adjust R120 (SIZE 1 MHz) to obtain a saturated marker on the oscilloscope display, with no spurious markers. A saturated marker is obtained when a further increase in size does not increase the marker amplitude on the display (it may be necessary to readjust the MARKERS SIZE to keep the marker on the screen). Increasing the adjustment beyond this point results in spurious markers.

e. Press the 50 MHz MARKERS button and adjust R130 (SIZE 10/50) for the same amplitude display as in step d.

This completes the calibration procedure.

CIRCUIT DESCRIPTION

4.1 GENERAL

Refer to the block diagram in Section 8 during the following discussion. There are four basic circuitry functions in the SW 503: (1) generating the sweep ramp voltage; (2) generating the rf output; (3) generating frequency markers; and (4) interfacing the unit to a frequency counter.

The sweep ramp generator circuit generates a triangular waveform that rises at the desired sweep speed. This ramp is applied to the sweep drive circuit, which sweeps the rf oscillator, and to the horizontal output, which is used to sweep the display oscilloscope.

The ramp is applied to the rf sweep oscillator, which produces an rf output. As the ramp voltage rises, the rf signal sweeps higher in frequency and the display oscilloscope trace moves to the right. As the ramp falls, the display retraces and the rf oscillator is turned off, providing a baseline. The frequency is determined by the instantaneous voltage level of the sweep drive ramp. If the ramp is stopped (dc output), the rf is a continuous wave. Varying the characteristics of the ramp by using the CTR FREQ and MAX SWEEP WIDTH controls provides control of the center frequency and the frequency range through which the unit sweeps.

The leveler compares a rectified rf output to a dc reference voltage. Any error between the two is amplified and sent to a voltage-variable attenuator in the sweep oscillator. This provides a flat rf output level over the entire frequency range. The VAR attenuator control can vary the dc reference in the leveler and thus control the rf output over a 20 dB range.

The marker circuits indicate the frequency of the rf output. Harmonic markers are selectable 1, 10 or 50 MHz apart. A sample of the rf from the sweep oscillator heterodynes with harmonics from a crystal-controlled oscillator signal to generate comb-type frequency markers. The markers are amplified and shaped in the marker amplifier, then added to the detected rf (from the device under test) and applied to the oscilloscope vertical.

The counter interface circuitry stops the sweep time ramp at the level set by the DOT POS control, and tells the counter to begin a count. When the counter finishes, sweep is resumed. Because of this sweep interruption, cw is provided to the counter (via the AUX RF output) and an intensified dot is displayed on the oscilloscope horizontal sweep that shows the location of the count.

Power supply regulators provide +18 V, -18 V, +33 V, -33 V, and +5 V for all of the circuits.

4.2 SWEEP RAMP GENERATOR

4.2.1 Basic Operation

The sweep ramp generator provides the ramp voltage that is used to sweep the rf generator and to sweep the horizontal axis of the display oscilloscope. It also provides a blanking signal that is used to turn off the rf generator and marker oscillator during sweep retrace. The output amplitude of the ramp is 10 V peak-to-peak (-5 V to +5 V). The blanking voltage switches between -18 V and +18 V. Figure 4-1 is a simplified diagram of the sweep ramp generator. The ramp risetime and negative blanking voltage correspond to the rf on-time (sweep); ramp falltime and positive blanking voltage correspond to the rf off-time (retrace).

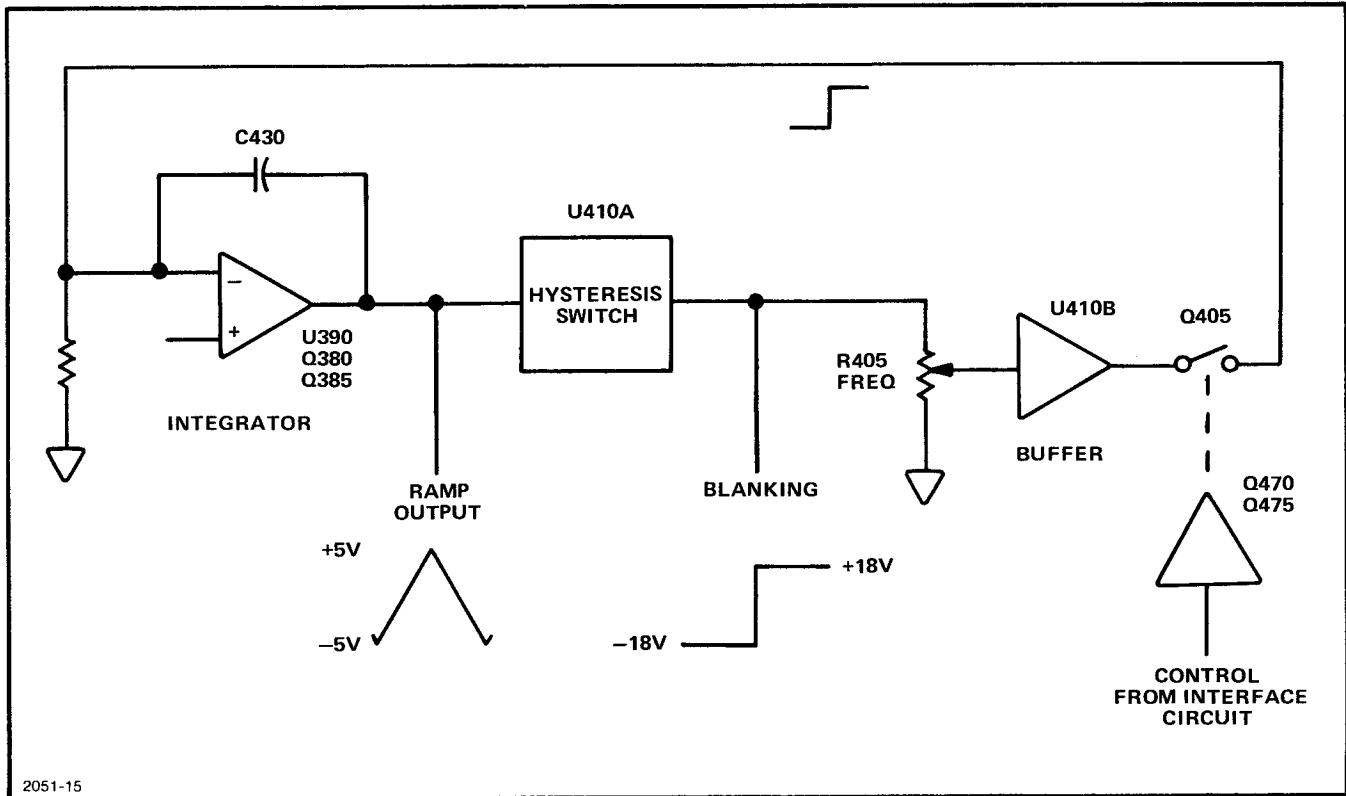

Figure 4-1. SW 503 sweep ramp generator (simplified diagram).

4.2.2 Ramp Generator

The ramp generator is an inverting integrator which includes U390, Q380, Q385, and C430, the integrating capacitor (refer to schematic). A positive dc level applied to U390 pin 2 causes the output to fall at a constant slope; a negative level causes the output to rise. These levels are generated by the hysteresis switch, described in the following paragraphs.

S372, the front panel SWEEP MODE/TIME switch, and five transistors (Q370, Q400, Q405, Q430, and Q450) switch in or out the appropriate circuitry for the desired function. The switching is not mentioned in the following discussions of the various modes.

The hysteresis switch includes U410A. The input voltage level required to switch the hysteresis switch is dependent upon its output voltage. When the output is positive (+18 V), the voltage (from the integrator) must fall to -5 V. When the hysteresis switch goes negative (-18 V), the input must rise to +5 V to switch it positive again. The hysteresis window (-5 V to +5 V) is determined by R394 and R402.

The blanking voltage output from the hysteresis switch is applied through Freq potentiometer R405 to buffer amplifier U410B. The sweep time is varied by controlling the feedback from the buffer output to the integrator input.

In the timed sweep modes (0.01 s, 0.1 s, 1 s, and 10 s per sweep), resistors R376, R378, R380, and R381 respectively determine the range. R375, the front panel VARIABLE control, adjusts the time within each range. Diode CR374 allows only the trace (rf on) time to be varied by R375, while the retrace is fixed at the fast end of the range. During the trace the feedback is a negative dc voltage, thus CR374 conducts and R375 can divide the voltage. During retrace the feedback is positive and the diode stops conducting; thus R375 acts like a series resistor which is negligible regardless of its position.

4.2.3 Single Sweep

SW370 is the PULL FOR SINGLE SWEEP switch on the rear of the VARIABLE control. Pulling the switch causes the sweep to stop at the end of retrace and await a trigger. The trigger may be provided by either the pushbutton TRIG switch, or remotely through the EXT CONTROL TRIG circuit.

The single sweep mode operates by enlarging the hysteresis window and clamping the integrator output before it reaches the hysteresis shifting point (refer to Basic Operation, Paragraph 4.2.1). The hysteresis window is shifted by CR404, which feeds back a positive output voltage. The decreasing ramp would therefore have to go farther negative than normal to switch the hysteresis switch. The integrator is clamped by a high-speed cycle of sensing the integrator output and controlling the integrator feedback to yield the proper output of -5 V dc. Comparator Q435 is off when the integrator output is more positive than -5 V. When it falls to -5 V, Q435 turns on, which turns on Q430 to provide negative feedback around the integrator. The resulting reduced gain causes the integrator output to become less negative, which turns Q435 off. This allows the integrator output to go more negative, starting the cycle over again. This sensing and correcting is so fast that the integrator output is essentially dc.

A single sweep is obtained by applying a negative pulse to the hysteresis switch, causing it to change to a negative output state. One sweep cycle occurs as in the variable rate mode, but since the positive hysteresis point is not shifted, the circuit waits at the end of the retrace. During the sweep, the trigger circuitry is disabled by a signal from the comparator until the sweep time ramp is clamped. At that time, Q435 turns on Q425, which turns on Q420, which applies power to Q460. Q460 inverts the signal on its base and applies it to a differentiating circuit (C460 and R462). When the TRIGGER button is pressed, the input to the differentiator goes from $+18$ V to 0 V and stays there until both the sweep time is again clamped and the button is released, when the voltage on the collector of Q460 is again reset to $+18$ V. The differentiator puts out a positive pulse when its input rises, and a negative pulse when the input falls. Q465 ignores the positive pulses and amplifies the negative pulses for application to the hysteresis switch.

4.2.4 Line Rate

In the LINE mode, the sweep time is adjusted by R370 to be one millisecond faster than one cycle of the ac power line. The trigger source is derived directly from the line voltage, and pulses the hysteresis switch at the beginning of the ac positive half-cycle. The single sweep feature and the VAR control do not function in the LINE mode.

4.2.5 CW Mode

The sweep ramp output is grounded in the CW mode since a swept signal is not necessary. The blanking voltage is held negative to maintain an rf output by applying a positive voltage through CR384 to pin 2 of U410A. This overrides any signal applied to pin 3.

4.2.6 MANual Mode

In the MANual mode, the rf output is swept manually by R375, the front panel VARIable control. In this mode, $+18$ V is applied to the VARIable control, and the variable output voltage is connected to the integrator, which functions as an inverting adder/attenuator. Its output swings between the same limits as before, -5 V to 5 V. The hysteresis switch and the buffer are both overridden to produce a negative output, which keeps the rf on.

4.3 SWEEP DRIVE CIRCUITRY

The sweep drive circuitry controls the rf output frequency by applying a combination of signals to the sweep oscillator module. The circuit consists of an input adder, a ramp shaping network, and an output amplifier.

4.3.1 Input Adder

This stage (U210A) combines the following signals:

1. Ramp derived from the sweep ramp generator (in the sweeping modes only). The amplitude of this ramp is controlled by the MAX SWEEP WIDTH controls. In the MANual and CW modes, a dc level is applied.

2. DC level between 0 and 10 V from the CTR FREQ control. In order to cause the correct positive or negative response to the CTR FREQ control, a negative voltage is added from Bal adjustment R185.

3. Input from EXT CONTROL FREQ connector. This input can be used to remotely control the center frequency of the sweep, or for modulating the output frequency when in the MANual or CW modes.

4.3.2 Ramp Shaping Network

This circuit compensates for the inherent nonlinearity of the rf oscillator during the time that corresponds to the rf output between 200 MHz and 400 MHz. The circuit adds to the linear ramp up to four different segments derived from it as shown in Figure 4-2. For the following discussion the CTR FREQ control is set to 200 MHz and the MAX SWEEP WIDTH controls are set for 400 MHz. This provides a maximum amplitude ramp out of the inverting input adder of equal positive and negative amplitudes. The shaping network effects the negative portion of this ramp.

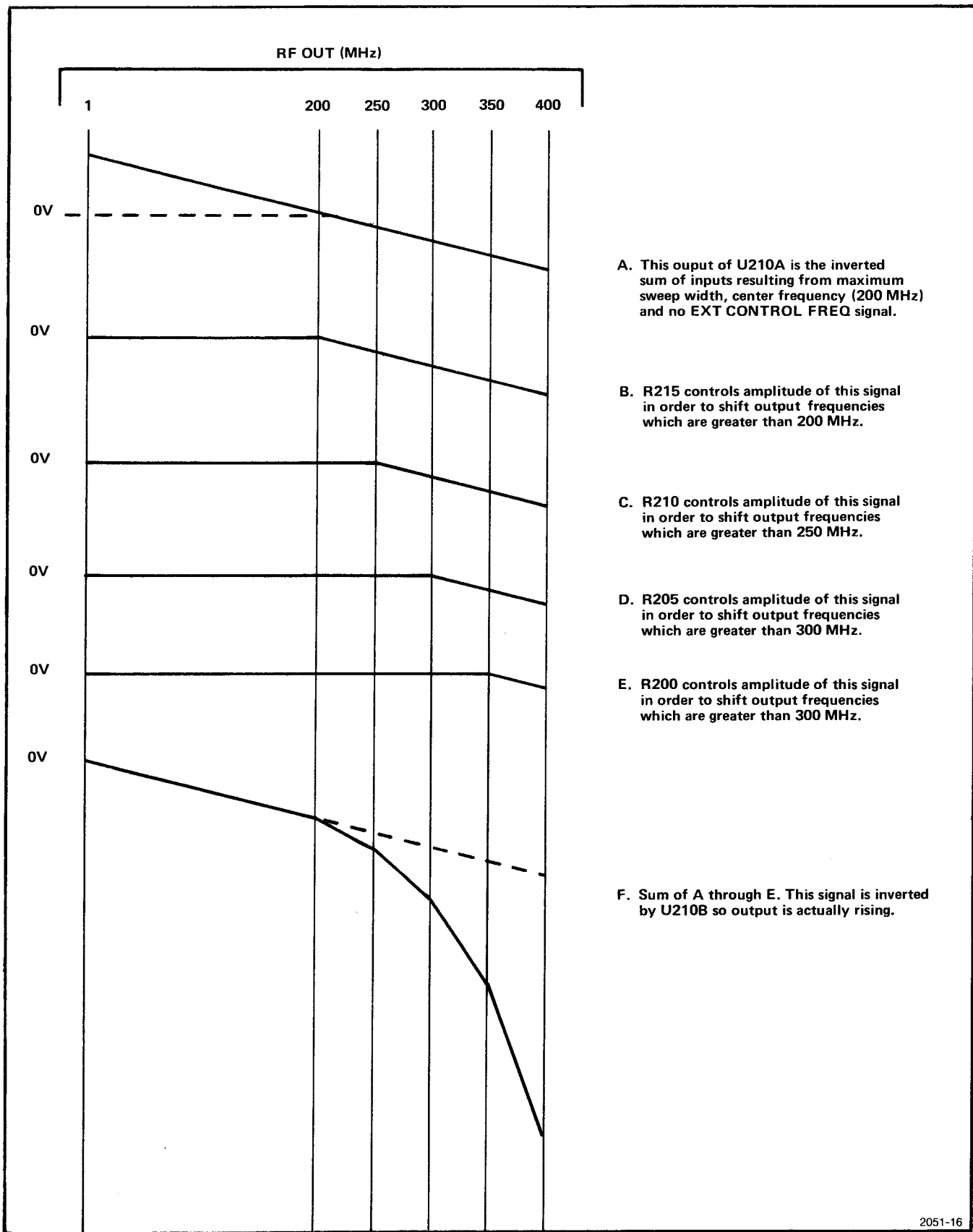

Figure 4-2. Ramp shaping network.

Referring to Figure 4-2, when ramp A falls below zero, CR210 conducts, thus adding ramp B to U210B. The amplitude of ramp B is determined by R215, which therefore controls the slope of the entire right half of the ramp (the slope can only be made steeper). When the voltage on the cathode of CR206 falls below zero the diode conducts, thus adding ramp C. The voltage applied to the cathode of CR206 is ramp A with a positive offset; therefore, a zero-volt level at this point occurs at a later point in time than did that at CR210. Inputs D and E are formed in a similar manner, using different offset levels. The offset levels are achieved by applying ramp A through a voltage divider to a constant-current source, Q190. Since the currents through the diodes are negligible, the voltage drops across resistors R196, R202, and R206 are constant.

4.3.3 Output Amplifier

U210B is an inverting operational amplifier. Its input adds the segments of ramp from the ramp shaping network (F in Figure 4-2). Its output drives the rf sweep generator module. Frequency adjustment R225 adjusts the gain, thus setting the zero-frequency point.

4.4 SWEEP OSCILLATOR MODULE

The rf sweep oscillator module A20 provides a swept or cw signal from 1 MHz to 400 MHz (refer to Figure 4-3). The swept signal is generated by heterodyning the output of a 1 GHz fixed-frequency oscillator with the output of a voltage-controlled oscillator that sweeps from approximately 1001 MHz to 1400 MHz. The difference frequency is amplified, and the output amplitude is controlled by the leveler circuit, described in Subsection 4.5. Center frequency calibration is provided by driving pin 8 of the module with a dc voltage determined by R235, the Freq 200 adjustment, and buffered by U230B.

4.5 RF OSCILLATOR LEVELER

The leveler circuit serves two purposes: It maintains a constant rf output amplitude at the sweep generator module output over the swept frequency range, and it allows output level adjustment or modulation via the front-panel CAL (attenuation) control of EXT CONTROL AMPL connector. The output is leveled by a detector, comparator, and voltage variable attenuator loop (see Figure 4-3). The detector and voltage variable attenuator are inside the rf oscillator module; U250A is the comparator. The detector outputs a dc voltage proportional to the rf amplitude at the various frequencies. If the voltage deviates from the dc reference, the comparator immediately changes the voltage to the voltage variable attenuator, thus increasing or decreasing the rf applied to the amplifier. The result is a flat rf output.

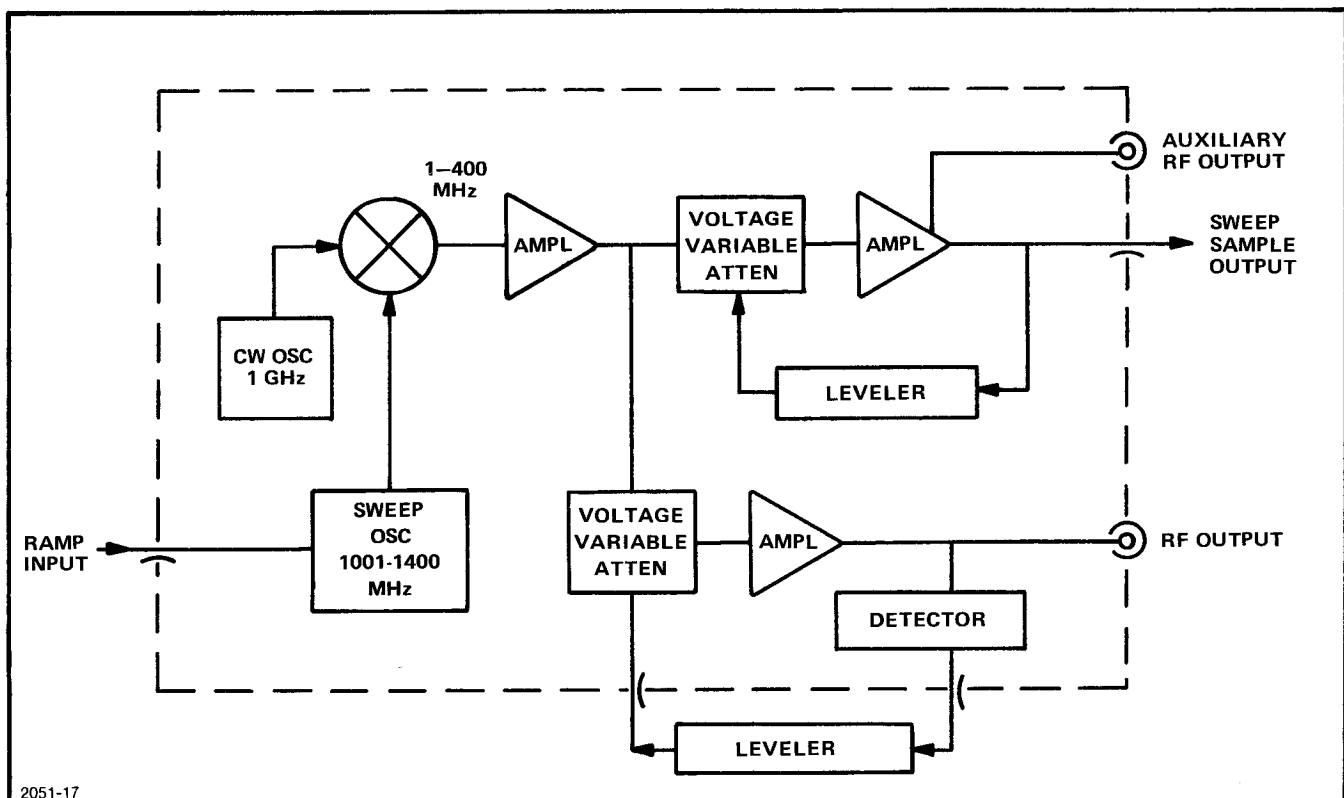
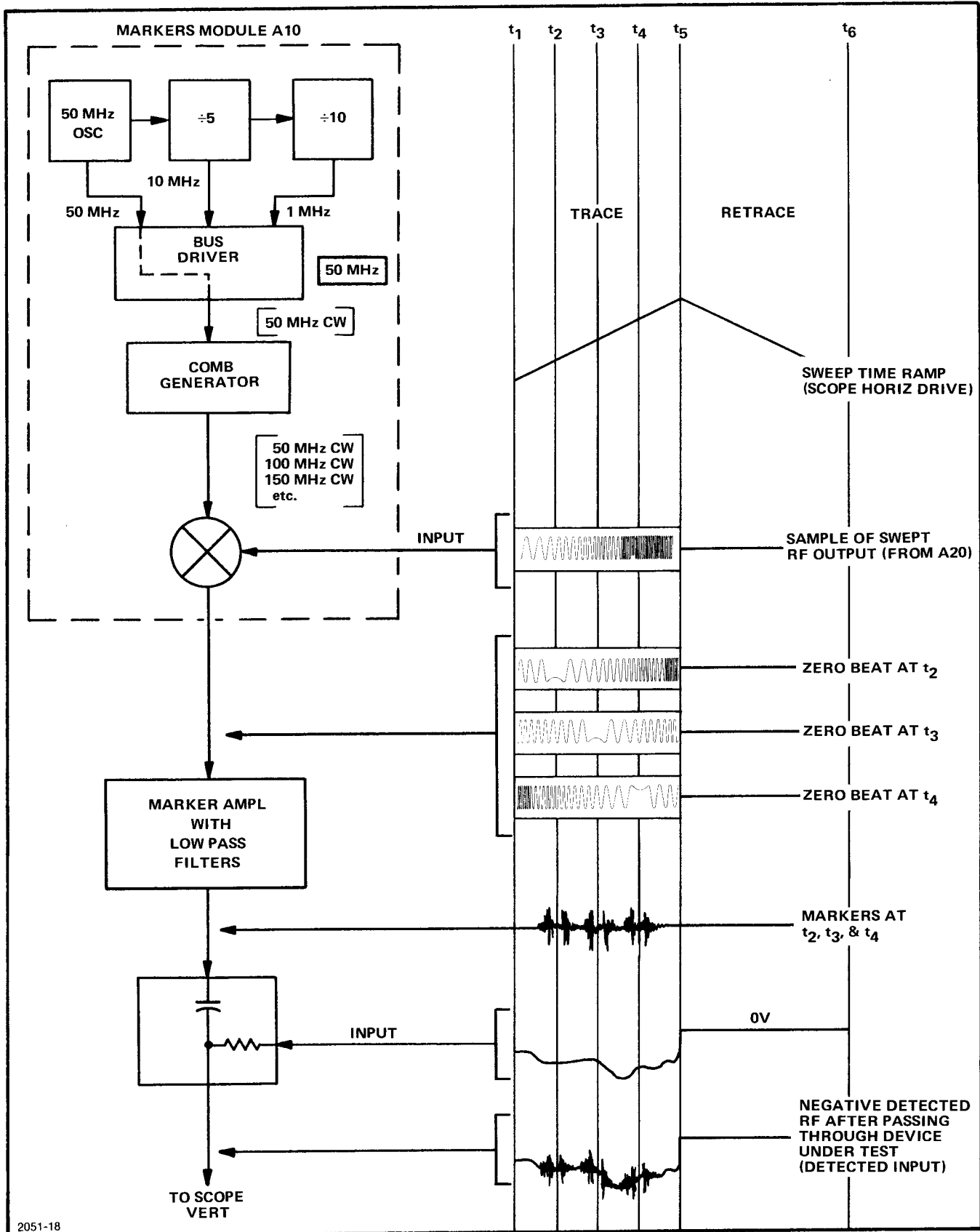

Figure 4-3. RF sweep oscillator module block diagram.



2051-18

Figure 4-4. Harmonic comb markers block diagram.

The output level is adjustable by varying the dc reference input to comparator U250A. The front-panel CAL potentiometer (R20) controls the rf output level over a 20 dB range; the range is adjusted by R240 and R245. The voltage applied to the CAL control is about -4.8 V from U250B when no external signal is applied. The EXT CONTROL AMPL connector permits applying an external signal to U250B to either provide external level control or amplitude modulation.

4.6 HARMONIC MARKER MODULE

The harmonic marker module mixes a sample of the rf output with one of three harmonic combs to generate a series of zero beat markers. The front-panel marker switch assembly includes three interlocking pushbuttons to allow only one harmonic marker output to operate at a time. See Figure 4-4 for a block diagram of the markers system.

The marker module contains a 50 MHz oscillator whose output is used directly, or counted down to 10 MHz or to 1 MHz. These three outputs are fed to an integrated circuit bus driver, where only one output is selected at a time. The driver output is applied to a step recovery diode which generates all harmonics of the applied frequency up to 400 MHz. This harmonic comb is then applied to a diode that mixes it with the sweep sample signal. The difference frequencies are a series of zero beats which are sent to the marker amplifier.

4.7 MARKER AMPLIFIER

The marker amplifier and its filters determine the size and shape of the markers before they are added to the detected rf signal (refer to Figure 4-4). The input, from the markers module, goes to a preamplifier consisting of Q110 and Q120. The preamplifier provides a high impedance input and a buffered output which feeds the Size 1 MHz adjustment. When the 10 MHz or 50 MHz markers are turned on, the marker switch assembly also sends a signal to Q130, which switches in an additional (Size 10/50) adjustment to attenuate the 10 and 50 MHz markers (which are normally larger than the 1 MHz markers). The markers then pass to Q135, whose load includes switchable width-determining circuitry. This circuitry maintains a visible marker by switching the marker width (marker frequency bandwidth) when the maximum sweep width is changed. Wide markers are achieved by applying $+18$ V to L140 and C140. In the medium width position, $+18$ V also turns on Q140 which connects C142 to ground. In the narrow width position, $+18$ V is removed from L140 and C140 and applied to Q140 and Q145, which shorts both C142 and C146 to ground. The markers are then amplified by operational amplifier U150 and applied to a push-pull stage (Q160 and Q165). The markers drive this stage into saturation so that each marker is the same size on the oscilloscope display. The markers pass through the front-panel SIZE control and an internal switch that selects either normal (attenuated) markers for addition to an oscilloscope display, or detected markers for addition to a chart recorder display (since a chart recorder pen cannot respond to the frequency of the undetected markers).

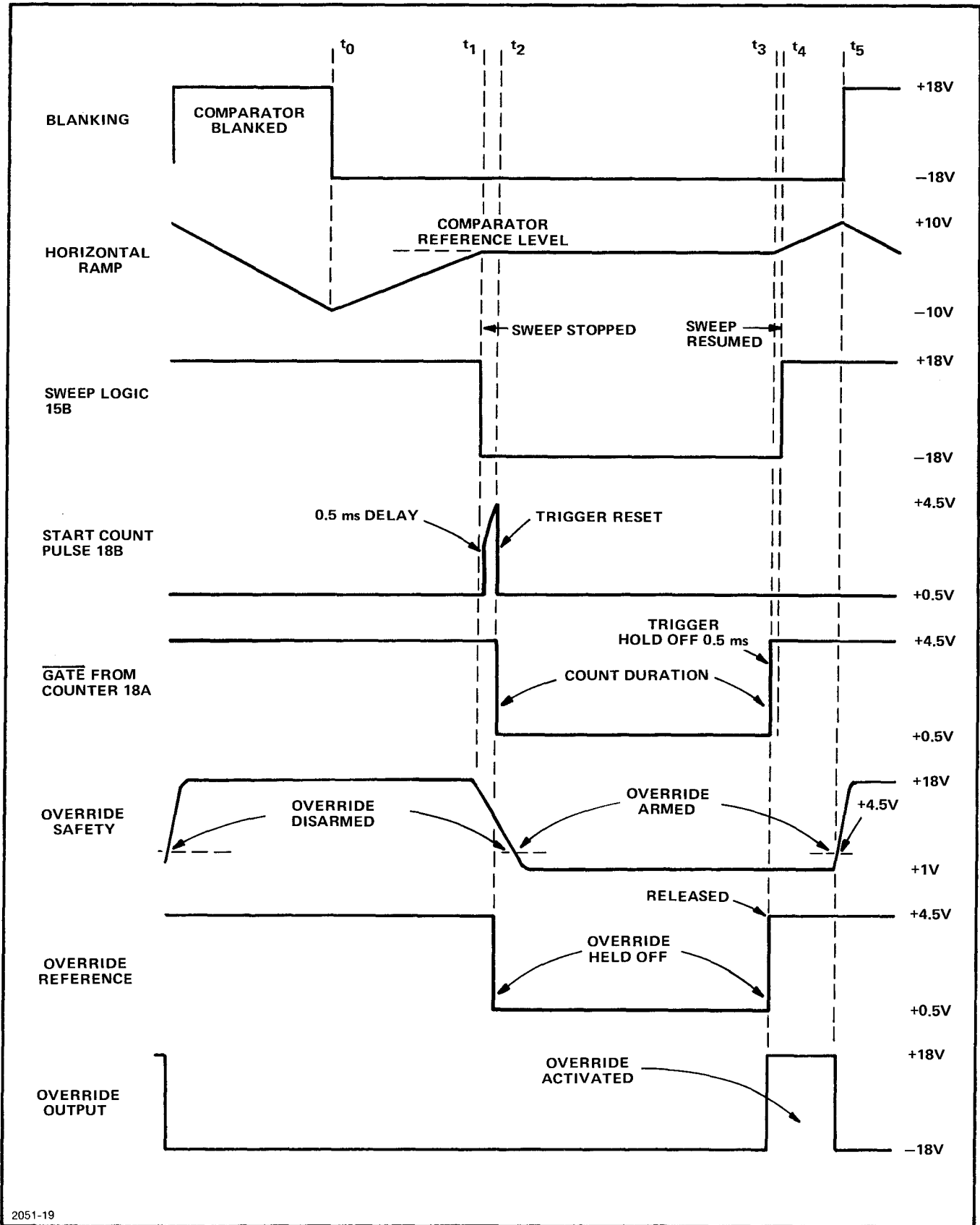

2051-19

Figure 4-5. Counter interface signals sequence.

4.8 COUNTER INTERFACE

The purpose of the counter interface is to stop the frequency sweep at some predetermined point, tell the counter to read the frequency at that point, then to continue the sweep from the point at which it was interrupted. The point at which the sweep stops is determined by the DOT POSITION control on the front panel. A visible dot indicating the counter frequency point is present only at the LINE and 0.01 s sweep rates. The following circuit discussion assumes the presence of a counter with sweep-interrupt logic, such as the DC 502 Option 7. Refer to Figure 4-5, as well as the schematic, for the following discussion, which follows the interface signals sequence.

Before t_0 —The SW 503 is executing retrace. The sweep ramp is falling, the blanking signal is +18 V, and the rf output is blanked off. The blanking signal is connected through CR294 to the noninverting input of comparator U280A. This overrides any other signal to the comparator, thus causing its output to be +18 V. The comparator drives an amplifier (Q470 and Q475) in the sweep ramp circuit which drives a FET switch. The positive comparator output closes the switch, thus closing the loop around the integrator/hysteresis switch oscillator, which maintains the ramp output.

t_0 —At time t_0 , the blanking signal switches to -18 V and the sweep ramp starts to rise. The rf generator is turned on and starts its sweep. The output of U280B is -18 V at this time, so CR290 prevents any effect on pin 2 of U280A. The comparator output remains positive until the instantaneous amplitude of the ramp signal to pin 2 of U280A is more positive than the dc level to pin 3, selected by the DOT POSITION control.

t_1 —When the ramp reaches the reference level, comparator U280A switches to -18 V. This opens Q405 and stops the integrator, which keeps the ramp from rising further. When the previously-positive output of U280A is no longer applied through CR296 to Q290, Q290 opens, its collector rising from 0.5 V to 4.5 V. This signal is sent to the counter, which starts counting. Before t_0 the +18 V blanking through CR292 charged up C290. CR292 allowed the charge to remain after the blanking went negative. At t_1 when U280A switches negative, C290 starts discharging through CR282, CR284, and CR286. CR288 limits discharge to about 1 V. Pin 6 reaches 1 V some time after t_2 .

t_2 —When the counter starts counting, the voltage applied to Q270 drops from 4.5 V to 0.5 V, turning it off and raising the collector from 0 to +18 V. This voltage is applied through CR274 to turn on Q290 again and reset the trigger pulse. The voltage is also applied to Q275, which turns on, dropping pin 5 of U280B from 4.5 V to 0 V.

Although pin 6 has been discharging since T_1 , its voltage remains higher than that on pin 5, thus output on pin 7 remains negative.

t_3 to t_4 —When the counter is done counting, pin 18A is switched to 4.5 V, which switches the collector of Q270 to 0 V. Q275 turns off, allowing pin 5 of U280B to be pulled up to 4.5 V. Since pin 6 is still about 1 V, U280B switches its output to +18 V. The positive voltage applied to U280A flips the output positive. The above sequence occurs between t_3 and t_4 . At t_3 , when the collector of Q270 goes to 0 V, the positive voltage is removed from CR274, but the charge on C296 keeps Q290 turned on until t_4 , when +18 V from U280A can take over holding Q290 on. The output of U280A, having switched positive, again closes the integrator/hysteresis switch loop by turning on Q405. The sweep ramp then continues to rise from the level at which it was stopped.

t_4 to t_5 —The override is activated by the relative voltages on the inputs of U280B. After t_4 there is no voltage source for C290, since the blanking signal is negative and the comparator output is positive. During very slow sweep times C290 tends to charge positively. To prevent U280B from switching negative, CR280 and R282 provide positive feedback.

t_5 —At t_5 the blanking signal returns positive. C290 is charged up again, causing the output to switch to -18 V. This allows U280A to again start comparing the ramp level to the level set by the MARKERS DOT POS control.

The SW 503 will not gate the counter in the MANUAL position of the SWEEP MODE/TIME switch. In this position, +18 V from the switch is applied through CR289 to pin 3 of U280A. This overrides any voltage on pin 2, thus keeping the output positive, which keeps the integrator/hysteresis switch loop closed and prevents a trigger to the counter.

When the counter is not present, the ground is removed from Q278, allowing pin 5 of U280B to rise to +18 V instead of +4.5 V. This maintains a positive voltage on the output of U280B and U280A, thereby ensuring that the integrator/hysteresis loop stays closed.

If, during normal operation, the counter is told by Q290 to start counting but the counter does not switch the signal to Q270 to 0.5 V, the circuit must be able to start the sweep time circuit again. If the input to Q270 remains at 4.5 V, pin 5 of U280B will remain at 4.5 V, and C290 will start to discharge at t_2 . When pin 6 falls below 4.5 V, U280B output will switch to +18 V, which causes the sweep cycle to start again.

IMPLEMENTING SPECIAL FEATURES

5.1 CHANGING HORIZONTAL OUTPUT VOLTAGE

The SW 503 SCOPE HORIZ (X-axis output), when in a sweeping mode, is a triangular waveform symmetrical about 0 V with an amplitude of 500 mV p-p, and an output impedance of 1 k Ω . For oscilloscopes or other display devices requiring a higher output voltage, the voltage is easily changed to 10 V p-p with an output impedance of 20 k Ω . To accomplish this, simply remove R25, the 1 k Ω resistor located between the rear of the SCOPE HORIZ connector and ground on the circuit board.

5.2 INTERFACE THROUGH REAR PLUG-IN CONNECTOR

5.2.1 Introduction

The SW 503 has provisions for interconnection with other units or control sources through the rear plug-in connector, thereby eliminating the need for some of the front panel connections. The features that can be duplicated through the rear connector are:

- Vertical output (SCOPE VERT)
- Horizontal output (SCOPE HORIZ)
- External trigger input (EXT CONTROL TRIG)
- Amplitude control (EXT CONTROL AMPL)
- Frequency control (EXT CONTROL FREQ)

The RF OUT, AUX RF, and DETECTED INPUT are not intended to be accessed through the rear connector due to the degradation of performance and potential crosstalk problems. Digital counter interface lines are described in Paragraph 5.2.7.

Refer to Figure 3-1 for connector P40 location, and to Figure 5-1 for rear plug-in connector contact locations. Note that both A and B sides of the rear plug-in connector can be soldered from either side of the circuit board.

5.2.2 Mainframe Modification

In addition to installing the wires as described below, the TM 500 Series mainframe must be modified by adding wires between the appropriate connector pins as necessary. When this is done, the mainframe generally becomes dedicated to a particular plug-in type, rather than accepting any TM 500 Series plug-in.

The digital counter interface lines are factory installed, when a mainframe with Option 7 is ordered. These particular lines can also be field-installed by ordering Field Modification Kit 040-0789-00.

CAUTION

When a Power Module compartment has been selected for the SW 503 and wired for a specialized interface system, a plastic barrier (Tektronix Part No. 214-1593-02) should be installed in a key slot between contacts 23 and 24 on the Power Module.

Do not insert any TM 500 Series plug-in in a live power module and do not use excessive force when inserting the plug-in.

5.2.3 Vertical Output (Y axis) and Horizontal Output (X axis)

a. Install a solder lug (such as Tektronix Part No. 210-0302-00) under the SCOPE HORIZ connector.

b. Strip the ends of a 12-inch length of miniature coaxial cable (such as Tektronix Part No. 175-1020-00). Refer to Figure 5-1 for the following steps.

c. For the vertical signal, solder the coaxial cable from the center pin of the SCOPE VERT connector (coax center conductor) and the ground lug (coax shield) to rear plug-in connector contact 28B (center conductor) and 28A (shield).

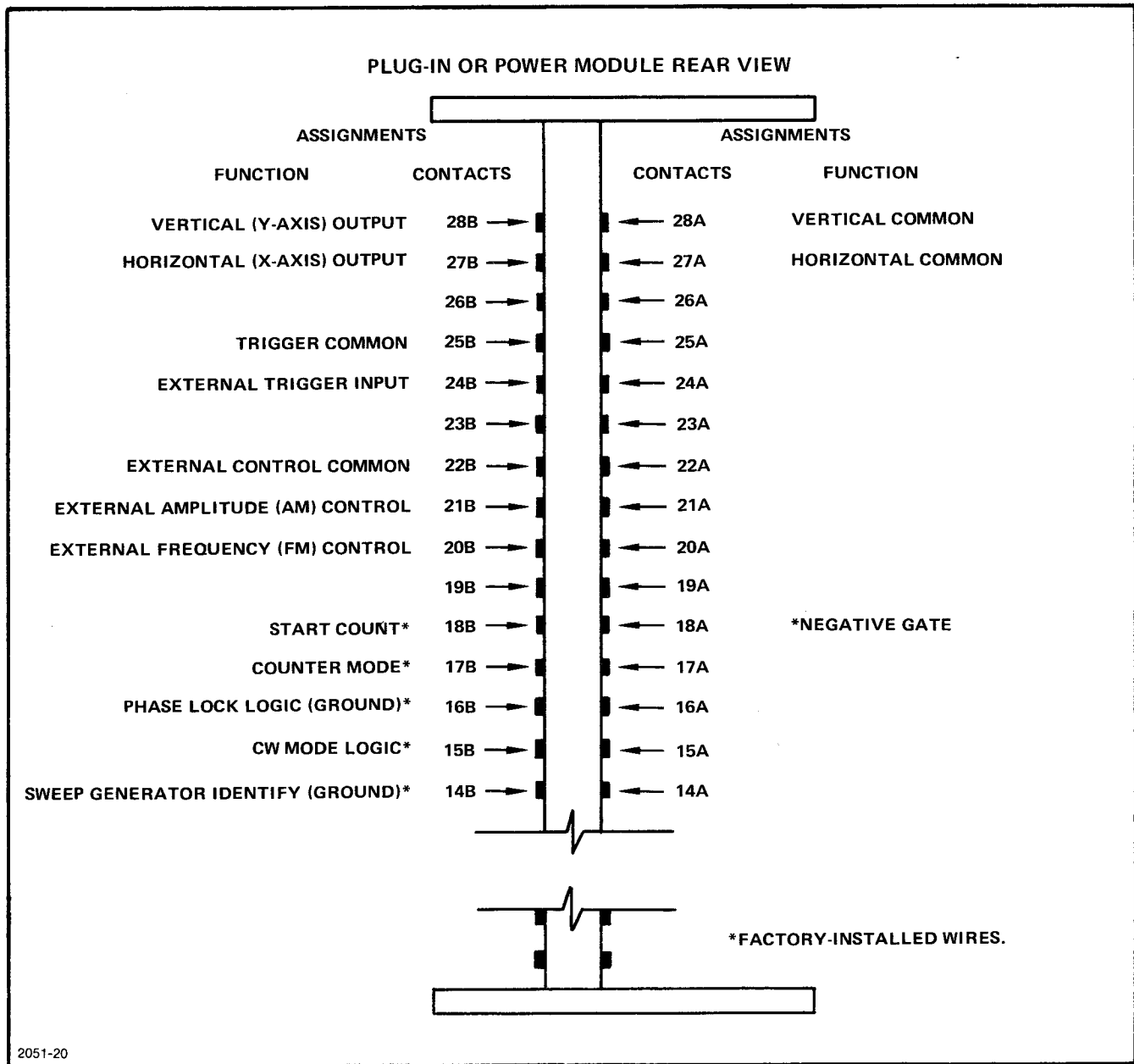

Figure 5-1. Rear plug-in connector P40 interface wiring.

d. For the horizontal signal, solder the coaxial cable from the center pin of the SCOPE HORIZ connector (coax center conductor) and the ground lug (coax shield) to rear plug-in connector contact 27B (coax center conductor) and 27A (shield).

5.2.4 External Frequency Control or Modulation

a. Connect a wire between P40 pin 4 (locate in Figure 3-4) and rear plug-in connector contact 20B (marked "FM" on board; locate in Figure 5-1).

b. Connect a wire between P40 pin 1 (GND) and rear plug-in connector contact 22B.

5.2.5 External Amplitude Control or Modulation

a. Connect a wire between P40 pin 3 (locate in Figure 3-4) and rear plug-in connector contact 21B (marked "AM" on board; locate in Figure 5-1).

b. Connect a wire (if not already installed) between P40 pin 1 (GND) and rear plug-in connector contact 22B.

5.2.6 External Trigger

a. Connect a wire between P40 pin 7 (locate in Figure 3-4) and rear plug-in connector contact 24B (marked "TRIG" on board; locate in Figure 5-1).

b. Connect a wire between P40 pin 1 (GND) and rear plug-in connector contact 25B.

5.2.7 Digital Counter Interface

The digital counter interface wires are factory-installed at contacts 14B through 18B and 18A, as denoted by

asterisks in Figure 5-1. These lines, described fully in the following table, are intended to interface with the DC 502 Option 7 Digital Counter; other counters may need to be modified. All lines use standard TTL voltages (0 V and +5 V). The six interface lines are used as indicated in Table 5-1.

Table 5-1
DIGITAL COUNTER INTERFACE LINES

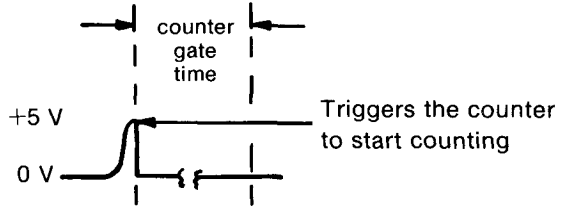
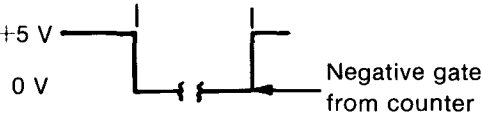
Line Name	Connector Contact Number	Description
Start count	B18	
GATE	A18	
Phase lock logic	B16	+5 V — — — 100 kHz resolution count 0 V — — — 10 Hz resolution count
CW Mode logic	B15	+5 V — — — Dot Marker Function 0 V — — — Normal counter functions
Sweep Generator Identify	B14	0 V — — — Grounded when SW 503 is plugged in
Counter Identify	B17	+5 V — — — Counter not installed in mainframe 0 V — — — Counter installed in mainframe

REPLACEABLE ELECTRICAL PARTS

PARTS ORDERING INFORMATION

Replacement parts are available from or through your local Tektronix, Inc. Field Office or representative.

Changes to Tektronix instruments are sometimes made to accommodate improved components as they become available, and to give you the benefit of the latest circuit improvements developed in our engineering department. It is therefore important, when ordering parts, to include the following information in your order: Part number, instrument type or number, serial number, and modification number if applicable.

If a part you have ordered has been replaced with a new or improved part, your local Tektronix, Inc. Field Office or representative will contact you concerning any change in part number.

Change information, if any, is located at the rear of this manual.

SPECIAL NOTES AND SYMBOLS

X000 Part first added at this serial number
00X Part removed after this serial number

ITEM NAME

In the Parts List, an Item Name is separated from the description by a colon (:). Because of space limitations, an Item Name may sometimes appear as incomplete. For further Item Name identification, the U.S. Federal Cataloging Handbook H6-1 can be utilized where possible.

ABBREVIATIONS

ACTR	ACTUATOR	PLSTC	PLASTIC
ASSY	ASSEMBLY	QTZ	QUARTZ
CAP	CAPACITOR	RECP	RECEPTACLE
CER	CERAMIC	RES	RESISTOR
CKT	CIRCUIT	RF	RADIO FREQUENCY
COMP	COMPOSITION	SEL	SELECTED
CONN	CONNECTOR	SEMICOND	SEMICONDUCTOR
ELCTLT	ELECTROLYTIC	SENS	SENSITIVE
ELEC	ELECTRICAL	VAR	VARIABLE
INCAND	INCANDESCENT	WW	WIREWOUND
LED	LIGHT EMITTING DIODE	XFMR	TRANSFORMER
NONWIR	NON WIREWOUND	XTAL	CRYSTAL

CROSS INDEX—MFR. CODE NUMBER TO MANUFACTURER

Mfr. Code	Manufacturer	Address	City, State, Zip
01121	ALLEN-BRADLEY COMPANY	1201 2ND STREET SOUTH	MILWAUKEE, WI 53204
01295	TEXAS INSTRUMENTS, INC., SEMICONDUCTOR GROUP	P O BOX 5012, 13500 N CENTRAL EXPRESSWAY	DALLAS, TX 75222
02111	SPECTROL ELECTRONICS CORPORATION	17070 EAST GALE AVENUE	CITY OF INDUSTRY, CA 91745
04222	AVX CERAMICS, DIVISION OF AVX CORP.	P O BOX 867, 19TH AVE. SOUTH	MURTL BEACH, SC 29577
04713	MOTOROLA, INC., SEMICONDUCTOR PROD. DIV.	5005 E MCDOWELL RD, PO BOX 20923	PHOENIX, AZ 85036
07910	TELEDYNE SEMICONDUCTOR	12515 CHADRON AVE.	HAWTHORNE, CA 90250
08806	GENERAL ELECTRIC CO., MINIATURE LAMP PRODUCTS DEPARTMENT	NELA PARK	CLEVELAND, OH 44112
27014	NATIONAL SEMICONDUCTOR CORP.	2900 SEMICONDUCTOR DR.	SANTA CLARA, CA 95051
32997	BOURNS, INC., TRIMPOT PRODUCTS DIV.	1200 COLUMBIA AVE.	RIVERSIDE, CA 92507
34280	WAVETEK INDIANA, INC.	PO BOX 190, 66N FIRST AVENUE	BEECH GROVE, IN 46107
56289	SPRAGUE ELECTRIC CO.		NORTH ADAMS, MA 01247
72982	ERIE TECHNOLOGICAL PRODUCTS, INC.	644 W. 12TH ST.	ERIE, PA 16512
73138	BECKMAN INSTRUMENTS, INC., HELIPOT DIV.	2500 HARBOR BLVD.	FULLERTON, CA 92634
73445	AMPEREX ELECTRONIC CORP.	230 DUFFY AVE.	HICKSVILLE, L. I., NY 11802
76493	BELL INDUSTRIES, INC., MILLER, J. W., DIV.	19070 REYES AVE., P O BOX 5825	COMPTON, CA 90224
80009	TEKTRONIX, INC.	P O BOX 500	BEAVERTON, OR 97077
91637	DALE ELECTRONICS, INC.	P. O. BOX 609	COLUMBUS, NE 68601

Ckt No.	Tektronix Part No.	Serial/Model No. Eff	Dscont	Name & Description	Mfr Code	Mfr Part Number
C10	281-0550-00			CAP.,FXD,CER DI:120PF,10%,500V	04222	7001-1373
C110	283-0333-00			CAP.,FXD,CER DI:35PF,5%,1000V	72982	858-000-COG-350J
C112	283-0000-00			CAP.,FXD,CER DI:0.001UF,+100-0%,500V	72982	831-516E102P
C114	283-0187-00			CAP.,FXD,CER DI:0.047UF,10%,400V	72982	8131N401X5R473K
C120	283-0187-00			CAP.,FXD,CER DI:0.047UF,10%,400V	72982	8131N401X5R473K
C138	290-0175-00			CAP.,FXD,ELCTLT:10UF,20%,35V	56289	150D106X0035R2
C140	283-0000-00			CAP.,FXD,CER DI:0.001UF,+100-0%,500V	72982	831-516E102P
C142	283-0104-00			CAP.,FXD,CER DI:2000PF,5%,500V	72982	811-565B202J
C144	283-0187-00			CAP.,FXD,CER DI:0.047UF,10%,400V	72982	8131N401X5R473K
C146	283-0204-00			CAP.,FXD,CER DI:0.01UF,20%,50V	72982	8121N075Z5U0103M
C154	283-0187-00			CAP.,FXD,CER DI:0.047UF,10%,400V	72982	8131N401X5R473K
C158	283-0187-00			CAP.,FXD,CER DI:0.047UF,10%,400V	72982	8131N401X5R473K
C162	290-0309-00			CAP.,FXD,ELCTLT:100UF,20%,25V	56289	109D107X0025F2
C166	290-0175-00			CAP.,FXD,ELCTLT:10UF,20%,35V	56289	150D106X0035R2
C176	290-0175-00			CAP.,FXD,ELCTLT:10UF,20%,35V	56289	150D106X0035R2
C217	290-0175-00			CAP.,FXD,ELCTLT:10UF,20%,35V	56289	150D106X0035R2
C234	290-0175-00			CAP.,FXD,ELCTLT:10UF,20%,35V	56289	150D106X0035R2
C256	283-0256-00			CAP.,FXD,CER DI:130PF,5%,100V	72982	8121B145P3K131J
C264	283-0077-00			CAP.,FXD,CER DI:330PF,5%,500V	56289	40C94A3
C290	290-0183-00			CAP.,FXD,ELCTLT:1UF,10%,35V	56289	162D105X9035CD2
C296	283-0104-00			CAP.,FXD,CER DI:2000PF,5%,500V	72982	811-565B202J
C301	290-0309-00			CAP.,FXD,ELCTLT:100UF,20%,25V	56289	109D107X0025F2
C304	283-0004-00			CAP.,FXD,CER DI:0.02UF,+80-20%,150V	72982	855-558-Z5V0203Z
C306	283-0000-00			CAP.,FXD,CER DI:0.001UF,+100-0%,500V	72982	831-516E102P
C312	290-0309-00			CAP.,FXD,ELCTLT:100UF,20%,25V	56289	109D107X0025F2
C314	283-0000-00			CAP.,FXD,CER DI:0.001UF,+100-0%,500V	72982	831-516E102P
C324	283-0004-00			CAP.,FXD,CER DI:0.02UF,+80-20%,150V	72982	855-558-Z5V0203Z
C326	290-0244-00			CAP.,FXD,ELCTLT:0.47UF,5%,35V	56289	162D474X5035BC2
C328	290-0309-00			CAP.,FXD,ELCTLT:100UF,20%,25V	56289	109D107X0025F2
C430	285-0930-00			CAP.,FXD,PLSTC:0.12UF,5%,200V	34280	CP103-415
C432	283-0078-00			CAP.,FXD,CER DI:0.001UF,20%,500V	56289	20C114A8
C444	283-0027-00			CAP.,FXD,CER DI:0.02UF,20%,50V	56289	273C32
C460	283-0027-00			CAP.,FXD,CER DI:0.02UF,20%,50V	56289	273C32
C464	283-0032-00			CAP.,FXD,CER DI:470PF,5%,500V	72982	831-500Z5D471J
C470	283-0347-00			CAP.,FXD,CER DI:68PF,5%,100V	72982	8121A108P3K680J
C514	283-0109-00			CAP.,FXD,CER DI:27PF,5%,1000V	56289	20C376
CR134	152-0066-00			SEMICONV DEVICE:SILICON,400V,750MA	80009	152-0066-00
CR136	152-0066-00			SEMICONV DEVICE:SILICON,400V,750MA	80009	152-0066-00
CR148	152-0066-00			SEMICONV DEVICE:SILICON,400V,750MA	80009	152-0066-00
CR190	152-0066-00			SEMICONV DEVICE:SILICON,400V,750MA	80009	152-0066-00
CR196	152-0066-00			SEMICONV DEVICE:SILICON,400V,750MA	80009	152-0066-00
CR200	152-0066-00			SEMICONV DEVICE:SILICON,400V,750MA	80009	152-0066-00
CR206	152-0066-00			SEMICONV DEVICE:SILICON,400V,750MA	80009	152-0066-00
CR210	152-0066-00			SEMICONV DEVICE:SILICON,400V,750MA	80009	152-0066-00
CR268	152-0066-00			SEMICONV DEVICE:SILICON,400V,750MA	80009	152-0066-00
CR274	152-0066-00			SEMICONV DEVICE:SILICON,400V,750MA	80009	152-0066-00
CR280	152-0066-00			SEMICONV DEVICE:SILICON,400V,750MA	80009	152-0066-00
CR282	152-0066-00			SEMICONV DEVICE:SILICON,400V,750MA	80009	152-0066-00
CR284	152-0066-00			SEMICONV DEVICE:SILICON,400V,750MA	80009	152-0066-00
CR286	152-0066-00			SEMICONV DEVICE:SILICON,400V,750MA	80009	152-0066-00
CR288	152-0066-00			SEMICONV DEVICE:SILICON,400V,750MA	80009	152-0066-00
CR289	152-0066-00			SEMICONV DEVICE:SILICON,400V,750MA	80009	152-0066-00

Replaceable Electrical Parts—SW 503

Ckt No.	Tektronix Part No.	Serial/Model No. Eff	Dscont	Name & Description	Mfr Code	Mfr Part Number
CR290	152-0066-00			SEMICON D DEVICE: SILICON, 400V, 750MA	80009	152-0066-00
CR292	152-0066-00			SEMICON D DEVICE: SILICON, 400V, 750MA	80009	152-0066-00
CR294	152-0066-00			SEMICON D DEVICE: SILICON, 400V, 750MA	80009	152-0066-00
CR296	152-0066-00			SEMICON D DEVICE: SILICON, 400V, 750MA	80009	152-0066-00
CR301	152-0066-00			SEMICON D DEVICE: SILICON, 400V, 750MA	80009	152-0066-00
CR304	152-0141-02			SEMICON D DEVICE: SILICON, 30V, 150MA	07910	1N4152
CR310	152-0141-02			SEMICON D DEVICE: SILICON, 30V, 150MA	07910	1N4152
CR312	152-0141-02			SEMICON D DEVICE: SILICON, 30V, 150MA	07910	1N4152
CR314	152-0141-02			SEMICON D DEVICE: SILICON, 30V, 150MA	07910	1N4152
CR316	152-0066-00			SEMICON D DEVICE: SILICON, 400V, 750MA	80009	152-0066-00
CR320	152-0141-02			SEMICON D DEVICE: SILICON, 30V, 150MA	07910	1N4152
CR374	152-0066-00			SEMICON D DEVICE: SILICON, 400V, 750MA	80009	152-0066-00
CR384	152-0066-00			SEMICON D DEVICE: SILICON, 400V, 750MA	80009	152-0066-00
CR404	152-0066-00			SEMICON D DEVICE: SILICON, 400V, 750MA	80009	152-0066-00
CR414	152-0066-00			SEMICON D DEVICE: SILICON, 400V, 750MA	80009	152-0066-00
CR450	152-0066-00			SEMICON D DEVICE: SILICON, 400V, 750MA	80009	152-0066-00
CR452	152-0066-00			SEMICON D DEVICE: SILICON, 400V, 750MA	80009	152-0066-00
CR454	152-0066-00			SEMICON D DEVICE: SILICON, 400V, 750MA	80009	152-0066-00
CR456	152-0066-00			SEMICON D DEVICE: SILICON, 400V, 750MA	80009	152-0066-00
CR458	152-0066-00			SEMICON D DEVICE: SILICON, 400V, 750MA	80009	152-0066-00
CR460	152-0066-00			SEMICON D DEVICE: SILICON, 400V, 750MA	80009	152-0066-00
CR472	152-0066-00			SEMICON D DEVICE: SILICON, 400V, 750MA	80009	152-0066-00
CR514	152-0129-00			SEMICON D DEVICE: GERMANIUM, 10V, 23UA	73445	1N87A
DS1	150-0048-01			LAMP, INCAND: 5V, 0.06A, SEL	08806	683AS15
L140	108-0324-00			COIL, RF: 10MH	76493	70F102A1
L160	108-0813-00			COIL, RF: 10UH	80009	108-0813-00
L166	108-0813-00			COIL, RF: 10UH	80009	108-0813-00
Q110	151-1005-00			TRANSISTOR: SILICON, JFE, N-CHANNEL	80009	151-1005-00
Q120	151-0639-00			TRANSISTOR: SILICON, NPN	80009	151-0639-00
Q130	151-1005-00			TRANSISTOR: SILICON, JFE, N-CHANNEL	80009	151-1005-00
Q135	151-0639-00			TRANSISTOR: SILICON, NPN	80009	151-0639-00
Q140	151-1005-00			TRANSISTOR: SILICON, JFE, N-CHANNEL	80009	151-1005-00
Q145	151-1005-00			TRANSISTOR: SILICON, JFE, N-CHANNEL	80009	151-1005-00
Q160	151-0641-00			TRANSISTOR: SILICON, PNP	80009	151-0641-00
Q165	151-0641-00			TRANSISTOR: SILICON, PNP	80009	151-0641-00
Q190	151-0219-00			TRANSISTOR: SILICON, PNP	80009	151-0219-00
Q250	151-1005-00			TRANSISTOR: SILICON, JFE, N-CHANNEL	80009	151-1005-00
Q270	151-0641-00			TRANSISTOR: SILICON, PNP	80009	151-0641-00
Q275	151-0641-00			TRANSISTOR: SILICON, PNP	80009	151-0641-00
Q290	151-0641-00			TRANSISTOR: SILICON, PNP	80009	151-0641-00
Q300	151-0190-00			TRANSISTOR: SILICON, NPN	80009	151-0190-00
Q305	151-0134-00			TRANSISTOR: SILICON, PNP	80009	151-0134-00
Q308	151-0190-00			TRANSISTOR: SILICON, NPN	80009	151-0190-00
Q310	151-0188-00			TRANSISTOR: SILICON, PNP	01295	2N3906
Q315	151-0103-00			TRANSISTOR: SILICON, NPN	04713	2N2219A
Q320	151-0188-00			TRANSISTOR: SILICON, PNP	01295	2N3906
Q360	151-0641-00			TRANSISTOR: SILICON, PNP	80009	151-0641-00
Q370	151-1005-00			TRANSISTOR: SILICON, JFE, N-CHANNEL	80009	151-1005-00
Q380	151-1005-00			TRANSISTOR: SILICON, JFE, N-CHANNEL	80009	151-1005-00
Q385	151-1005-00			TRANSISTOR: SILICON, JFE, N-CHANNEL	80009	151-1005-00
Q400	151-1005-00			TRANSISTOR: SILICON, JFE, N-CHANNEL	80009	151-1005-00
Q405	151-1005-00			TRANSISTOR: SILICON, JFE, N-CHANNEL	80009	151-1005-00

Ckt No.	Tektronix Part No.	Serial/Model No. Eff	Dscont	Name & Description	Mfr Code	Mfr Part Number
Q420	151-1005-00			TRANSISTOR:SILICON,JFE,N-CHANNEL	80009	151-1005-00
Q425	151-0638-00			TRANSISTOR:SILICON,PNP	80009	151-0638-00
Q430	151-1005-00			TRANSISTOR:SILICON,JFE,N-CHANNEL	80009	151-1005-00
Q435	151-0641-00			TRANSISTOR:SILICON,PNP	80009	151-0641-00
Q450	151-1005-00			TRANSISTOR:SILICON,JFE,N-CHANNEL	80009	151-1005-00
Q460	151-0638-00			TRANSISTOR:SILICON,PNP	80009	151-0638-00
Q465	151-0638-00			TRANSISTOR:SILICON,PNP	80009	151-0638-00
Q470	151-0637-00			TRANSISTOR:SILICON,NPN	80009	151-0637-00
Q475	151-0640-00			TRANSISTOR:SILICON,PNP	80009	151-0640-00
R5	118-0084-00			RES.,VAR,WW:10K OHM,5%,1.5W	32997	3610S-534-103
R10	315-0105-00			RES.,FXD,CMPSN:1M OHM,5%,0.25W	01121	CB1055
R15	315-0473-00			RES.,FXD,CMPSN:47K OHM,5%,0.25W	01121	CB4735
R20	-----			RESISTOR,VAR:10K OHM	34280	RF146-310
R25	321-0193-00			RES.,FXD,FILM:1K OHM,1%,0.125W	91637	MFF1816G10000F
R110	315-0105-00			RES.,FXD,CMPSN:1M OHM,5%,0.25W	01121	CB1055
R112	315-0822-00			RES.,FXD,CMPSN:8.2K OHM,5%,0.25W	01121	CB8225
R114	315-0153-00			RES.,FXD,CMPSN:15K OHM,5%,0.25W	01121	CB1535
R116	315-0102-00			RES.,FXD,CMPSN:1K OHM,5%,0.25W	01121	CB1025
R118	315-0474-00			RES.,FXD,CMPSN:470K OHM,5%,0.25W	01121	CB4745
R120	311-1559-00			RES.,VAR,NONWIR:10K OHM,20%,0.50W	73138	91A-10001M
R122	315-0103-00			RES.,FXD,CMPSN:10K OHM,5%,0.25W	01121	CB1035
R124	315-0103-00			RES.,FXD,CMPSN:10K OHM,5%,0.25W	01121	CB1035
R126	315-0104-00			RES.,FXD,CMPSN:100K OHM,5%,0.25W	01121	CB1045
R128	315-0475-00			RES.,FXD,CMPSN:4.7M OHM,5%,0.25W	01121	CB4755
R130	311-1134-00			RES.,VAR,NONWIR:50K OHM,20%,0.50W	73138	72XW-S1-0-503M
R132	315-0332-00			RES.,FXD,CMPSN:3.3K OHM,5%,0.25W	01121	CB3325
R134	315-0271-00			RES.,FXD,CMPSN:270 OHM,5%,0.25W	01121	CB2715
R136	315-0106-00			RES.,FXD,CMPSN:10M OHM,5%,0.25W	01121	CB1065
R138	315-0103-00			RES.,FXD,CMPSN:10K OHM,5%,0.25W	01121	CB1035
R140	315-0103-00			RES.,FXD,CMPSN:10K OHM,5%,0.25W	01121	CB1035
R142	315-0106-00			RES.,FXD,CMPSN:10M OHM,5%,0.25W	01121	CB1065
R144	315-0105-00			RES.,FXD,CMPSN:1M OHM,5%,0.25W	01121	CB1055
R146	315-0106-00			RES.,FXD,CMPSN:10M OHM,5%,0.25W	01121	CB1065
R148	315-0105-00			RES.,FXD,CMPSN:1M OHM,5%,0.25W	01121	CB1055
R150	315-0224-00			RES.,FXD,CMPSN:220K OHM,5%,0.25W	01121	CB2245
R152	315-0103-00			RES.,FXD,CMPSN:10K OHM,5%,0.25W	01121	CB1035
R154	315-0182-00			RES.,FXD,CMPSN:1.8K OHM,5%,0.25W	01121	CB1825
R156	315-0103-00			RES.,FXD,CMPSN:10K OHM,5%,0.25W	01121	CB1035
R158	315-0103-00			RES.,FXD,CMPSN:10K OHM,5%,0.25W	01121	CB1035
R160	315-0102-00			RES.,FXD,CMPSN:1K OHM,5%,0.25W	01121	CB1025
R162	315-0681-00			RES.,FXD,CMPSN:680 OHM,5%,0.25W	01121	CB6815
R164	315-0102-00			RES.,FXD,CMPSN:1K OHM,5%,0.25W	01121	CB1025
R166	315-0681-00			RES.,FXD,CMPSN:680 OHM,5%,0.25W	01121	CB6815
R170	315-0474-00			RES.,FXD,CMPSN:470K OHM,5%,0.25W	01121	CB4745
R172	315-0101-00			RES.,FXD,CMPSN:100 OHM,5%,0.25W	01121	CB1015
R174	321-0310-00			RES.,FXD,FILM:16.5K OHM,1%,0.125W	91637	MFF1816G16501F
R176	315-0203-00			RES.,FXD,CMPSN:20K OHM,5%,0.25W	01121	CB2035
R180	311-1148-00			RES.,VAR,NONWIR:100K OHM,20%,0.50W	32997	3386M-T07-104
R182	321-0409-00			RES.,FXD,FILM:178K OHM,1%,0.125W	91637	MFF1816G17802F
R184	321-0409-00			RES.,FXD,FILM:178K OHM,1%,0.125W	91637	MFF1816G17802F
R185	311-1558-00			RES.,VAR,NONWIR:20K OHM,20%,0.50W	73138	91A R20K
R186	321-0409-00			RES.,FXD,FILM:178K OHM,1%,0.125W	91637	MFF1816G17802F
R188	315-0103-00			RES.,FXD,CMPSN:10K OHM,5%,0.25W	01121	CB1035

Replaceable Electrical Parts—SW 503

Ckt No.	Tektronix Part No.	Serial/Model No. Eff	Dscont	Name & Description	Mfr Code	Mfr Part Number
R190	315-0472-03			RES., FXD, CMPSN:4.7K OHM, 5%, 0.25W	01121	CB4725
R192	315-0272-00			RES., FXD, CMPSN:2.7K OHM, 5%, 0.25W	01121	CB2725
R194	315-0472-03			RES., FXD, CMPSN:4.7K OHM, 5%, 0.25W	01121	CB4725
R195	311-1558-00			RES., VAR, NONWIR:20K OHM, 20%, 0.50W	73138	91A R20K
R196	315-0102-00			RES., FXD, CMPSN:1K OHM, 5%, 0.25W	01121	CB1025
R200	311-1148-00			RES., VAR, NONWIR:100K OHM, 20%, 0.50W	32997	3386M-T07-104
R201	315-0124-00			RES., FXD, CMPSN:120K OHM, 5%, 0.25W	01121	CB1245
R202	315-0102-00			RES., FXD, CMPSN:1K OHM, 5%, 0.25W	01121	CB1025
R204	315-0224-00			RES., FXD, CMPSN:220K OHM, 5%, 0.25W	01121	CB2245
R205	311-1148-00			RES., VAR, NONWIR:100K OHM, 20%, 0.50W	32997	3386M-T07-104
R206	315-0102-00			RES., FXD, CMPSN:1K OHM, 5%, 0.25W	01121	CB1025
R210	311-1148-00			RES., VAR, NONWIR:100K OHM, 20%, 0.50W	32997	3386M-T07-104
R211	315-0474-02			RES., FXD, CMPSN:470K OHM, 5%, 0.25W	01121	CB4745
R212	315-0224-00			RES., FXD, CMPSN:220K OHM, 5%, 0.25W	01121	CB2245
R213	315-0824-00			RES., FXD, CMPSN:820K OHM, 5%, 0.25W	01121	CB8245
R214	315-0334-00			RES., FXD, CMPSN:330K OHM, 5%, 0.25W	01121	CB3345
R215	311-1148-00			RES., VAR, NONWIR:100K OHM, 20%, 0.50W	32997	3386M-T07-104
R216	315-0474-00			RES., FXD, CMPSN:470K OHM, 5%, 0.25W	01121	CB4745
R217	315-0183-00			RES., FXD, CMPSN:18K OHM, 5%, 0.25W	01121	CB1835
R220	315-0753-00			RES., FXD, CMPSN:75K OHM, 5%, 0.25W	01121	CB7535
R224	315-0103-00			RES., FXD, CMPSN:10K OHM, 5%, 0.25W	01121	CB1035
R225	311-1558-00			RES., VAR, NONWIR:20K OHM, 20%, 0.50W	73138	91A R20K
R230	315-0103-00			RES., FXD, CMPSN:10K OHM, 5%, 0.25W	01121	CB1035
R232	315-0103-00			RES., FXD, CMPSN:10K OHM, 5%, 0.25W	01121	CB1035
R234	315-0472-03			RES., FXD, CMPSN:4.7K OHM, 5%, 0.25W	01121	CB4725
R235	311-1559-00			RES., VAR, NONWIR:10K OHM, 20%, 0.50W	73138	91A-10001M
R236	315-0101-00			RES., FXD, CMPSN:100 OHM, 5%, 0.25W	01121	CB1015
R240	311-1558-00			RES., VAR, NONWIR:20K OHM, 20%, 0.50W	73138	91A R20K
R242	315-0103-00			RES., FXD, CMPSN:10K OHM, 5%, 0.25W	01121	CB1035
R244	315-0103-00			RES., FXD, CMPSN:10K OHM, 5%, 0.25W	01121	CB1035
R245	311-1558-00			RES., VAR, NONWIR:20K OHM, 20%, 0.50W	73138	91A R20K
R246	315-0103-00			RES., FXD, CMPSN:10K OHM, 5%, 0.25W	01121	CB1035
R247	315-0334-00			RES., FXD, CMPSN:330K OHM, 5%, 0.25W	01121	CB3345
R250	315-0105-00			RES., FXD, CMPSN:1M OHM, 5%, 0.25W	01121	CB1055
R252	315-0225-00			RES., FXD, CMPSN:2.2M OHM, 5%, 0.25W	01121	CB2255
R254	315-0684-00			RES., FXD, CMPSN:680K OHM, 5%, 0.25W	01121	CB6845
R256	315-0102-00			RES., FXD, CMPSN:1K OHM, 5%, 0.25W	01121	CB1025
R260	315-0102-00			RES., FXD, CMPSN:1K OHM, 5%, 0.25W	01121	CB1025
R262	321-0343-00			RES., FXD, FILM:36.5K OHM, 1%, 0.125W	91637	MFF1816G36501F
R264	315-0103-00			RES., FXD, CMPSN:10K OHM, 5%, 0.25W	01121	CB1035
R266	315-0103-00			RES., FXD, CMPSN:10K OHM, 5%, 0.25W	01121	CB1035
R267	321-0316-00			RES., FXD, FILM:19.1K OHM, 1%, 0.125W	91637	MFF1816G19101F
R268	315-0103-00			RES., FXD, CMPSN:10K OHM, 5%, 0.25W	01121	CB1035
R269	315-0200-00			RES., FXD, CMPSN:20 OHM, 5%, 0.25W	01121	CB2005
R270	315-0303-00			RES., FXD, CMPSN:30K OHM, 5%, 0.25W	01121	CB3035
R271	315-0332-00			RES., FXD, CMPSN:3.3K OHM, 5%, 0.25W	01121	CB3325
R272	315-0332-00			RES., FXD, CMPSN:3.3K OHM, 5%, 0.25W	01121	CB3325
R276	315-0752-00			RES., FXD, CMPSN:7.5K OHM, 5%, 0.25W	01121	CB7525
R278	315-0103-00			RES., FXD, CMPSN:10K OHM, 5%, 0.25W	01121	CB1035
R280	315-0333-00			RES., FXD, CMPSN:33K OHM, 5%, 0.25W	01121	CB3335
R282	315-0332-00			RES., FXD, CMPSN:3.3K OHM, 5%, 0.25W	01121	CB3325
R284	315-0102-00			RES., FXD, CMPSN:1K OHM, 5%, 0.25W	01121	CB1025
R288	315-0222-00			RES., FXD, CMPSN:2.2K OHM, 5%, 0.25W	01121	CB2225

Ckt No.	Tektronix Part No.	Serial/Model No. Eff	Dscont	Name & Description	Mfr Code	Mfr Part Number
R290	315-0153-00			RES., FXD, CMPSN:15K OHM, 5%, 0.25W	01121	CB1535
R292	315-0472-03			RES., FXD, CMPSN:4.7K OHM, 5%, 0.25W	01121	CB4725
R294	315-0752-00			RES., FXD, CMPSN:7.5K OHM, 5%, 0.25W	01121	CB7525
R296	315-0682-00			RES., FXD, CMPSN:6.8K OHM, 5%, 0.25W	01121	CB6825
R298	315-0103-00			RES., FXD, CMPSN:10K OHM, 5%, 0.25W	01121	CB1035
R300	308-0365-00			RES., FXD, WW:1.5 OHM, 5%, 3W	56289	242EX1R500JQ151
R302	315-0472-03			RES., FXD, CMPSN:4.7K OHM, 5%, 0.25W	01121	CB4725
R304	315-0472-03			RES., FXD, CMPSN:4.7K OHM, 5%, 0.25W	01121	CB4725
R306	315-0103-00			RES., FXD, CMPSN:10K OHM, 5%, 0.25W	01121	CB1035
R307	315-0822-00			RES., FXD, CMPSN:8.2K OHM, 5%, 0.25W	01121	CB8225
R308	301-0560-00			RES., FXD, CMPSN:56 OHM, 5%, 0.50W	01121	EB5605
R309	301-0682-00			RES., FXD, CMPSN:6.8K OHM, 5%, 0.50W	01121	EB6825
R310	311-1138-00			RES., VAR, NONWIR:1K OHM, 20%, 0.50W	73138	72XW-44-0-102
R311	321-0251-00			RES., FXD, FILM:4.02K OHM, 1%, 0.125W	91637	MFF1816G40200F
R312	321-0230-00			RES., FXD, FILM:2.43K OHM, 1%, 0.125W	91637	MFF1816G24300F
R313	321-0289-00			RES., FXD, FILM:10K OHM, 1%, 0.125W	91637	MFF1816G10001F
R314	301-0560-00			RES., FXD, CMPSN:56 OHM, 5%, 0.50W	01121	EB5605
R316	315-0472-03			RES., FXD, CMPSN:4.7K OHM, 5%, 0.25W	01121	CB4725
R317	321-0289-00			RES., FXD, FILM:10K OHM, 1%, 0.125W	91637	MFF1816G10001F
R318	315-0472-03			RES., FXD, CMPSN:4.7K OHM, 5%, 0.25W	01121	CB4725
R321	301-0682-00			RES., FXD, CMPSN:6.8K OHM, 5%, 0.50W	01121	EB6825
R322	308-0365-00			RES., FXD, WW:1.5 OHM, 5%, 3W	56289	242EX1R500JQ151
R350	311-1558-00			RES., VAR, NONWIR:20K OHM, 20%, 0.50W	73138	91A R20K
R352	321-0306-01			RES., FXD, FILM:15K OHM, 0.5%, 0.125W	91637	MFF1816G15001D
R354	321-0306-01			RES., FXD, FILM:15K OHM, 0.5%, 0.125W	91637	MFF1816G15001D
R356	315-0103-00			RES., FXD, CMPSN:10K OHM, 5%, 0.25W	01121	CB1035
R360	315-0153-00			RES., FXD, CMPSN:15K OHM, 5%, 0.25W	01121	CB1535
R362	315-0472-00			RES., FXD, CMPSN:4.7K OHM, 5%, 0.25W	01121	CB4725
R364	315-0103-00			RES., FXD, CMPSN:10K OHM, 5%, 0.25W	01121	CB1035
R370	311-1164-00			RES., FXD, NONWIR:50K OHM, 20%	32997	3386M-T07-503
R372	315-0333-00			RES., FXD, CMPSN:33K OHM, 5%, 0.25W	01121	CB3335
R374	315-0271-00			RES., FXD, CMPSN:270 OHM, 5%, 0.25W	01121	CB2715
R375	-----			RESISTOR, VAR:10K OHM	34280	RP145-310
R376	321-0354-00			RES., FXD, FILM:47.5K OHM, 1%, 0.125W	91637	MFF1816G47501F
R378	315-0474-00			RES., FXD, CMPSN:470K OHM, 5%, 0.25W	01121	CB4745
R380	315-0475-00			RES., FXD, CMPSN:4.7M OHM, 5%, 0.25W	01121	CB4755
R381	316-0476-00			RES., FXD, CMPSN:47M OHM, 10%, 0.25W	01121	CB4761
R382	315-0104-00			RES., FXD, CMPSN:100K OHM, 5%, 0.25W	01121	CB1045
R383	315-0393-00			RES., FXD, CMPSN:39K OHM, 5%, 0.25W	01121	CB3935
R384	315-0107-00			RES., FXD, CMPSN:100M OHM, 5%, 0.25W	01121	CB1075
R386	315-0472-00			RES., FXD, CMPSN:4.7K OHM, 5%, 0.25W	01121	CB4725
R390	315-0473-00			RES., FXD, CMPSN:47K OHM, 5%, 0.25W	01121	CB4735
R392	315-0473-00			RES., FXD, CMPSN:47K OHM, 5%, 0.25W	01121	CB4735
R394	321-0300-00			RES., FXD, FILM:13K OHM, 1%, 0.125W	91637	MFF1816G13001F
R396	315-0104-00			RES., FXD, CMPSN:100K OHM, 5%, 0.25W	01121	CB1045
R398	315-0106-00			RES., FXD, CMPSN:10M OHM, 5%, 0.25W	01121	CB1065
R400	315-0103-00			RES., FXD, CMPSN:10K OHM, 5%, 0.25W	01121	CB1035
R401	315-0105-00			RES., FXD, CMPSN:1M OHM, 5%, 0.25W	01121	CB1055
R402	321-0351-00			RES., FXD, FILM:44.2K OHM, 1%, 0.125W	91637	MFF1816G44201F
R404	315-0224-00			RES., FXD, CMPSN:220K OHM, 5%, 0.25W	01121	CB2245
R405	311-1558-00			RES., VAR, NONWIR:20K OHM, 20%, 0.50W	73138	91A R20K
R406	315-0472-00			RES., FXD, CMPSN:4.7K OHM, 5%, 0.25W	01121	CB4725
R408	315-0472-00			RES., FXD, CMPSN:4.7K OHM, 5%, 0.25W	01121	CB4725

Replaceable Electrical Parts—SW 503

Ckt No.	Tektronix Part No.	Serial/Model No. Eff Dscont	Name & Description	Mfr Code	Mfr Part Number
R410	315-0103-00		RES.,FXD,CMPSN:10K OHM,5%,0.25W	01121	CB1035
R412	315-0103-00		RES.,FXD,CMPSN:10K OHM,5%,0.25W	01121	CB1035
R414	315-0103-00		RES.,FXD,CMPSN:10K OHM,5%,0.25W	01121	CB1035
R416	315-0105-00		RES.,FXD,CMPSN:1M OHM,5%,0.25W	01121	CB1055
R420	315-0104-00		RES.,FXD,CMPSN:100K OHM,5%,0.25W	01121	CB1045
R422	315-0104-00		RES.,FXD,CMPSN:100K OHM,5%,0.25W	01121	CB1045
R424	315-0103-00		RES.,FXD,CMPSN:10K OHM,5%,0.25W	01121	CB1035
R426	315-0223-00		RES.,FXD,CMPSN:22K OHM,5%,0.25W	01121	CB2235
R428	315-0223-00		RES.,FXD,CMPSN:22K OHM,5%,0.25W	01121	CB2235
R430	315-0106-00		RES.,FXD,CMPSN:10M OHM,5%,0.25W	01121	CB1065
R432	315-0273-00		RES.,FXD,CMPSN:27K OHM,5%,0.25W	01121	CB2735
R435	311-1164-00		RES.,FXD,NONWIR:50K OHM,20%	32997	3386M-T07-503
R435	311-1246-00		RES.,VAR,NONWIR:50K OHM,10%,0.50W	02111	63X-503-T602
R436	315-0203-00		RES.,FXD,CMPSN:20K OHM,5%,0.25W	01121	CB2035
R438	315-0683-00		RES.,FXD,CMPSN:68K OHM,5%,0.25W	01121	CB6835
R440	315-0104-00		RES.,FXD,CMPSN:100K OHM,5%,0.25W	01121	CB1045
R442	315-0104-00		RES.,FXD,CMPSN:100K OHM,5%,0.25W	01121	CB1045
R444	315-0106-00		RES.,FXD,CMPSN:10M OHM,5%,0.25W	01121	CB1065
R446	315-0104-00		RES.,FXD,CMPSN:100K OHM,5%,0.25W	01121	CB1045
R448	315-0472-00		RES.,FXD,CMPSN:4.7K OHM,5%,0.25W	01121	CB4725
R450	315-0104-00		RES.,FXD,CMPSN:100K OHM,5%,0.25W	01121	CB1045
R460	315-0103-00		RES.,FXD,CMPSN:10K OHM,5%,0.25W	01121	CB1035
R461	315-0563-00		RES.,FXD,CMPSN:56K OHM,5%,0.25W	01121	CB5635
R462	315-0102-00		RES.,FXD,CMPSN:1K OHM,5%,0.25W	01121	CB1025
R464	315-0473-00		RES.,FXD,CMPSN:47K OHM,5%,0.25W	01121	CB4735
R470	315-0104-00		RES.,FXD,CMPSN:100K OHM,5%,0.25W	01121	CB1045
R472	315-0103-00		RES.,FXD,CMPSN:10K OHM,5%,0.25W	01121	CB1035
R474	315-0104-00		RES.,FXD,CMPSN:100K OHM,5%,0.25W	01121	CB1045
R476	315-0473-00		RES.,FXD,CMPSN:47K OHM,5%,0.25W	01121	CB4735
R500	321-0306-00		RES.,FXD,FILM:15K OHM,1%,0.125W	91637	MFF1816G15001F
R502	321-0289-00		RES.,FXD,FILM:10K OHM,1%,0.125W	91637	MFF1816G10001F
R504	321-0176-00		RES.,FXD,FILM:665 OHM,1%,0.125W	91637	MFF1816G665ROF
R505	118-0067-00		RESISTOR,VAR:10K OHM,5.5MM SHAFT	80009	118-0067-00
R510	118-0068-00		RESISTOR,VAR:10K OHM,5.5MM SHAFT	80009	118-0068-00
R512	315-0153-00		RES.,FXD,CMPSN:15K OHM,5%,0.25W	01121	CB1535
R514	315-0102-00		RES.,FXD,CMPSN:1K OHM,5%,0.25W	01121	CB1025
S360	118-0053-00		DOT MKR SWP AS:	80009	118-0053-00
S370	118-0053-00		DOT MKR SWP AS:	80009	118-0053-00
S372	118-0053-00		DOT MKR SWP AS:	80009	118-0053-00
S500	118-0052-00		CKT CARD ASSY:ATTEN BRKT AND MARKER	80009	118-0052-00
S502	118-0052-00		CKT CARD ASSY:ATTEN BRKT AND MARKER	80009	118-0052-00
S504	118-0052-00		CKT CARD ASSY:ATTEN BRKT AND MARKER	80009	118-0052-00
S510	118-0052-00		CKT CARD ASSY:ATTEN BRKT AND MARKER	80009	118-0052-00
S512	118-0052-00		CKT CARD ASSY:ATTEN BRKT AND MARKER	80009	118-0052-00
S514	118-0052-00		CKT CARD ASSY:ATTEN BRKT AND MARKER	80009	118-0052-00
S516	118-0052-00		CKT CARD ASSY:ATTEN BRKT AND MARKER	80009	118-0052-00
U150	156-0742-00		MICROCIRCUIT,LI:OPERATIONAL AMPLIFIER	80009	156-0742-00
U210A	156-0158-00		MICROCIRCUIT,LI:DUAL OPERATIONAL AMPLIFIER	80009	156-0158-00
U210B	156-0158-00		MICROCIRCUIT,LI:DUAL OPERATIONAL AMPLIFIER	80009	156-0158-00
U230A	156-0158-00		MICROCIRCUIT,LI:DUAL OPERATIONAL AMPLIFIER	80009	156-0158-00
U230B	156-0158-00		MICROCIRCUIT,LI:DUAL OPERATIONAL AMPLIFIER	80009	156-0158-00
U250A	156-0158-00		MICROCIRCUIT,LI:DUAL OPERATIONAL AMPLIFIER	80009	156-0158-00

Ckt No.	Tektronix Part No.	Serial/Model No. Eff	Dscont	Name & Description	Mfr Code	Mfr Part Number
U250B	156-0158-00			MICROCIRCUIT, LI:DUAL OPERATIONAL AMPLIFIER	80009	156-0158-00
U280A	156-0158-00			MICROCIRCUIT, LI:DUAL OPERATIONAL AMPLIFIER	80009	156-0158-00
U280B	156-0158-00			MICROCIRCUIT, LI:DUAL OPERATIONAL AMPLIFIER	80009	156-0158-00
U325	156-0277-00			MICROCIRCUIT, LI:VOLTAGE REGULATOR	27014	LM340T-5
U390	156-0067-00			MICROCIRCUIT, LI:OPERATIONAL AMPLIFIER	80009	156-0067-00
U410A,B	156-0158-00			MICROCIRCUIT, LI:DUAL OPERATIONAL AMPLIFIER	80009	156-0158-00
VR304	152-0309-00			SEMICONV DEVICE:ZENER, 1W, 6.2V, 5%	04713	1N3828A
VR308	152-0278-00			SEMICONV DEVICE:ZENER, 0.4W, 3V, 5%	07910	1N4372A
VR320	152-0278-00			SEMICONV DEVICE:ZENER, 0.4W, 3V, 5%	07910	1N4372A

OPTIONS

OPTION 1

Option 1 is described throughout the manual where appropriate.

DIAGRAMS AND CIRCUIT BOARD ILLUSTRATIONS

Symbols and Reference Designators

Electrical components shown on the diagrams are in the following units unless noted otherwise:

- Capacitors = Values one or greater are in picofarads (pF).
Values less than one are in microfarads (μ F).
- Resistors = Ohms (Ω).

Symbols used on the diagrams are based on ANSI Standard Y32.2-1975.

Logic symbology is based on ANSI Y32.14-1973 in terms of positive logic. Logic symbols depict the logic function performed and may differ from the manufacturer's data.

The following prefix letters are used as reference designators to identify components or assemblies on the diagrams.

A	Assembly, separable or repairable (circuit board, etc.)	H	Heat dissipating device (heat sink, heat radiator, etc.)	S	Switch or contactor
AT	Attenuator, fixed or variable	HR	Heater	T	Transformer
B	Motor	HY	Hybrid circuit	TC	Thermocouple
BT	Battery	J	Connector, stationary portion	TP	Test point
C	Capacitor, fixed or variable	K	Relay	U	Assembly, inseparable or non-repairable (integrated circuit, etc.)
CB	Circuit breaker	L	Inductor, fixed or variable	V	Electron tube
CR	Diode, signal or rectifier	M	Meter	VR	Voltage regulator (zener diode, etc.)
DL	Delay line	P	Connector, movable portion	W	Wirestrap or cable
DS	Indicating device (lamp)	Q	Transistor or silicon-controlled rectifier	Y	Crystal
E	Spark Gap	R	Resistor, fixed or variable	Z	Phase shifter
F	Fuse	RT	Thermistor		
FL	Filter				

The following special symbols are used on the diagrams:

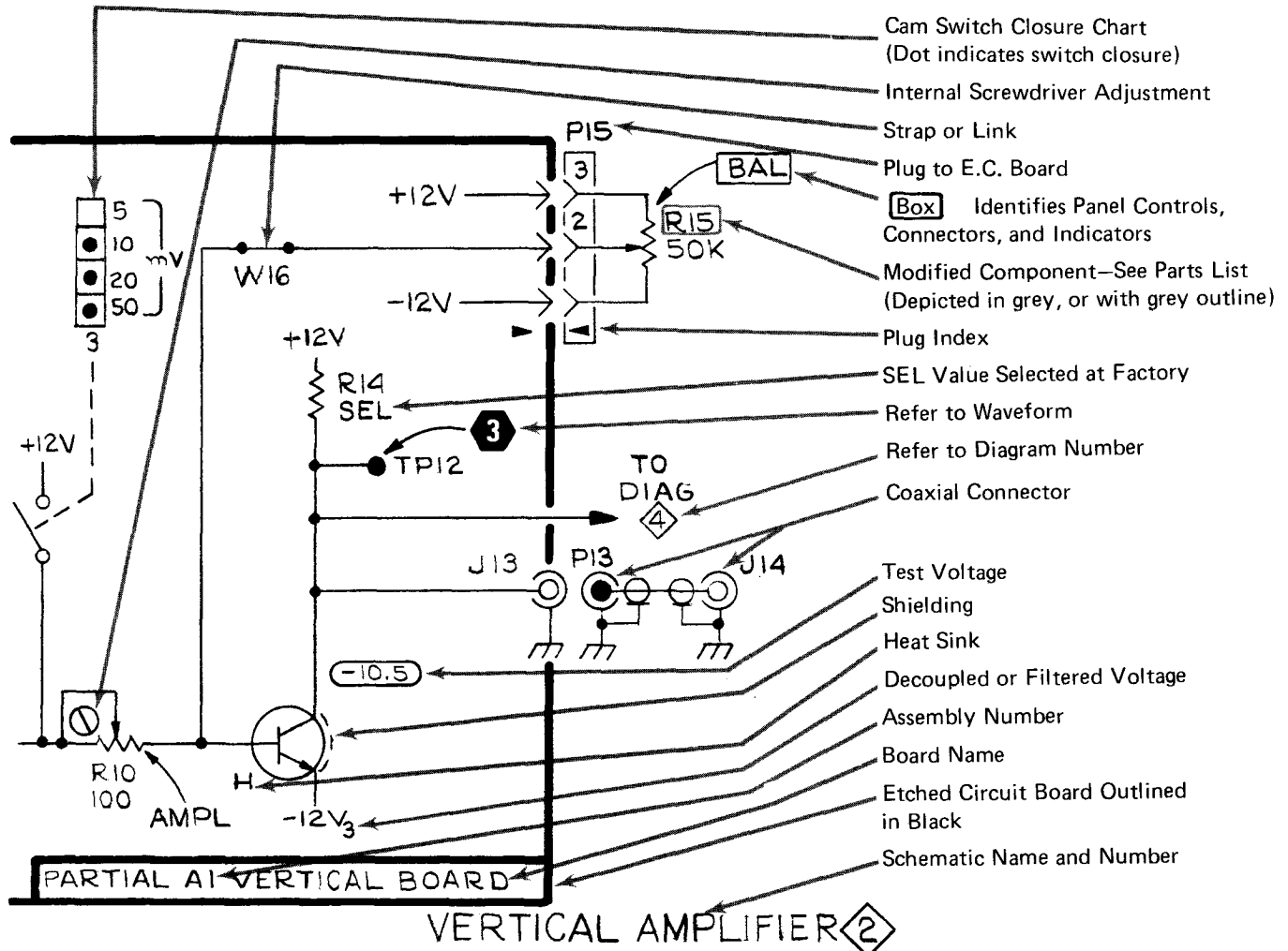

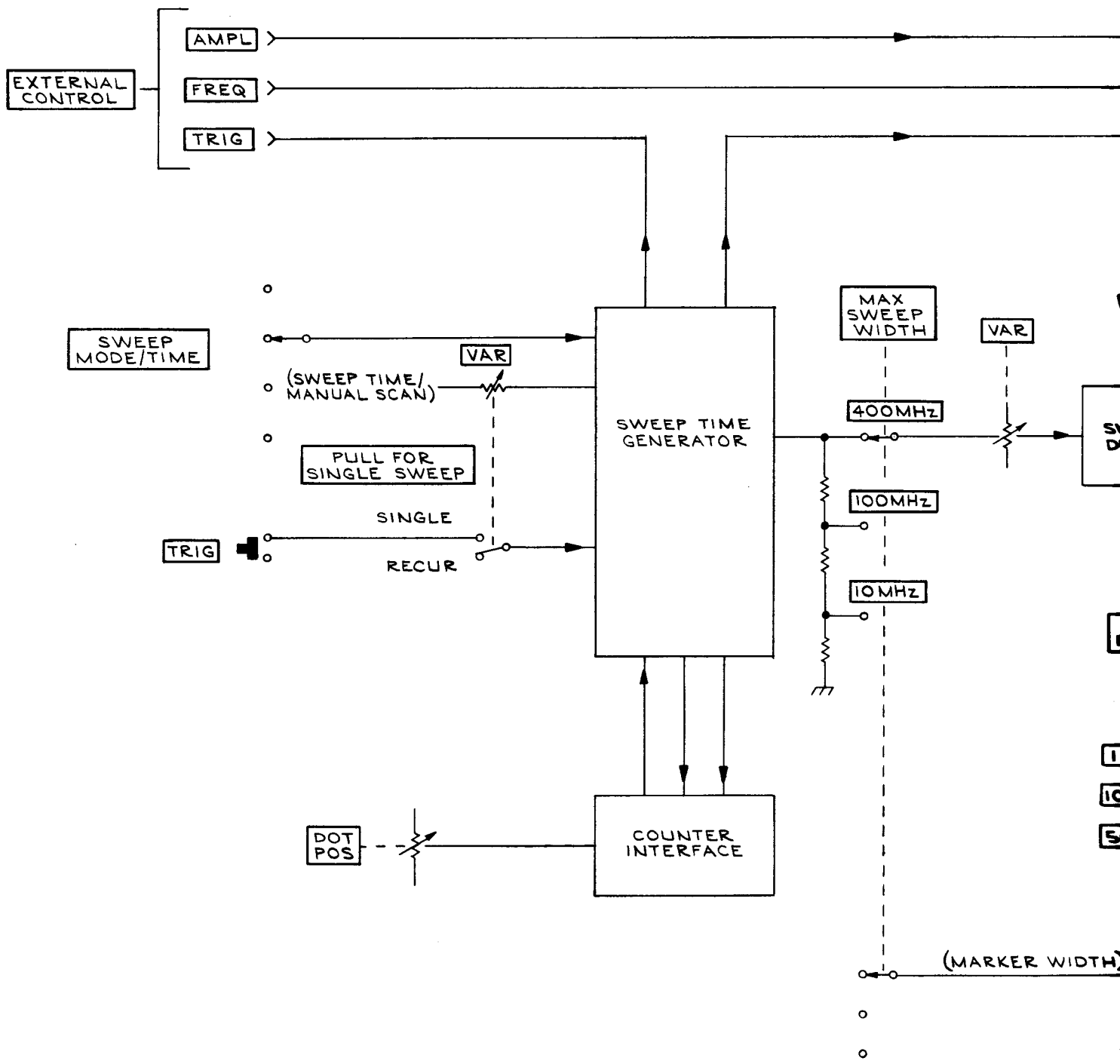

SW503

@

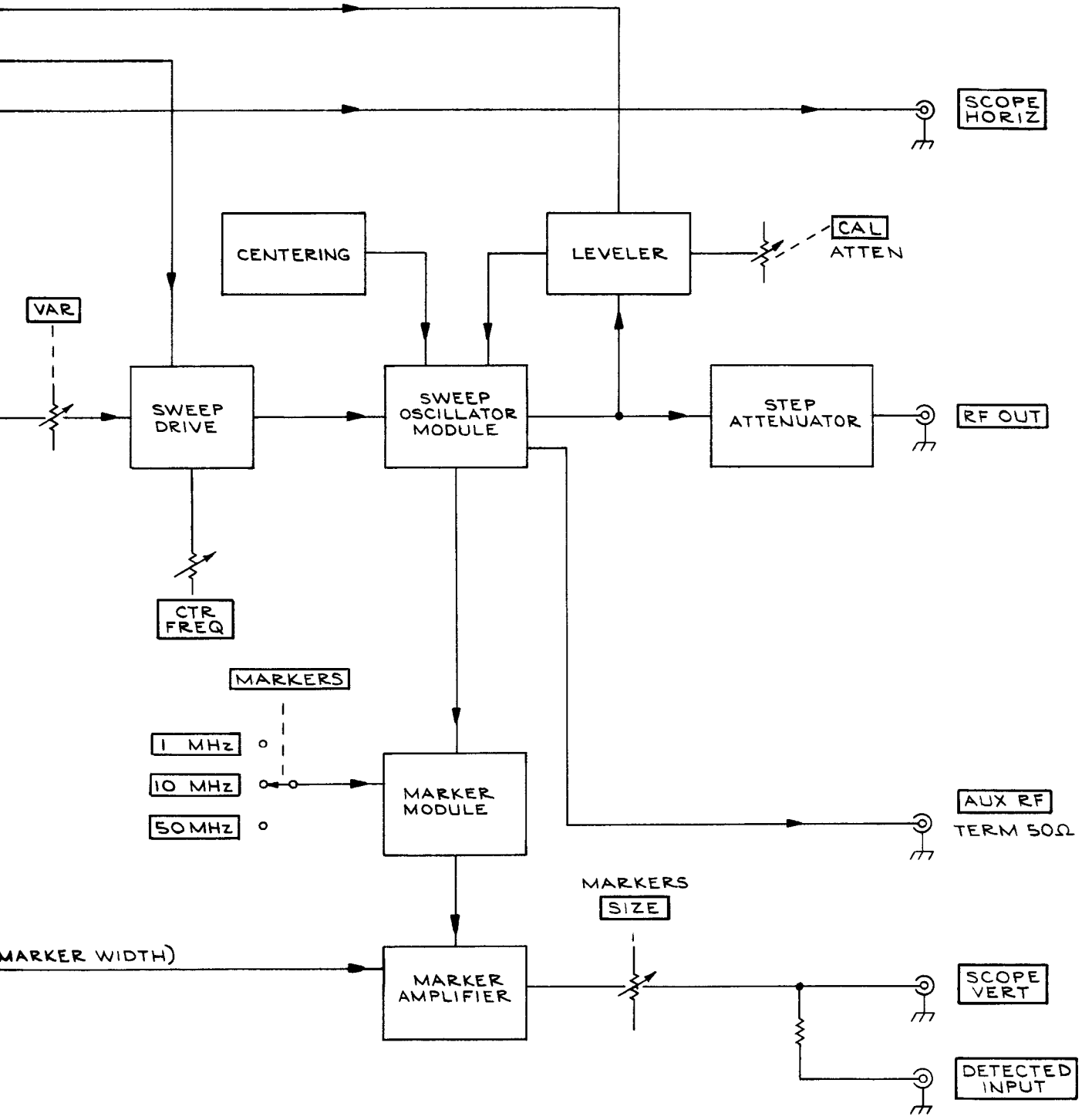

BLOCK DIAGRAM

1

BLOCK DIAGRAM 1 576 DJ

2

COMPONENT LOCATION FOR DIAGRAM

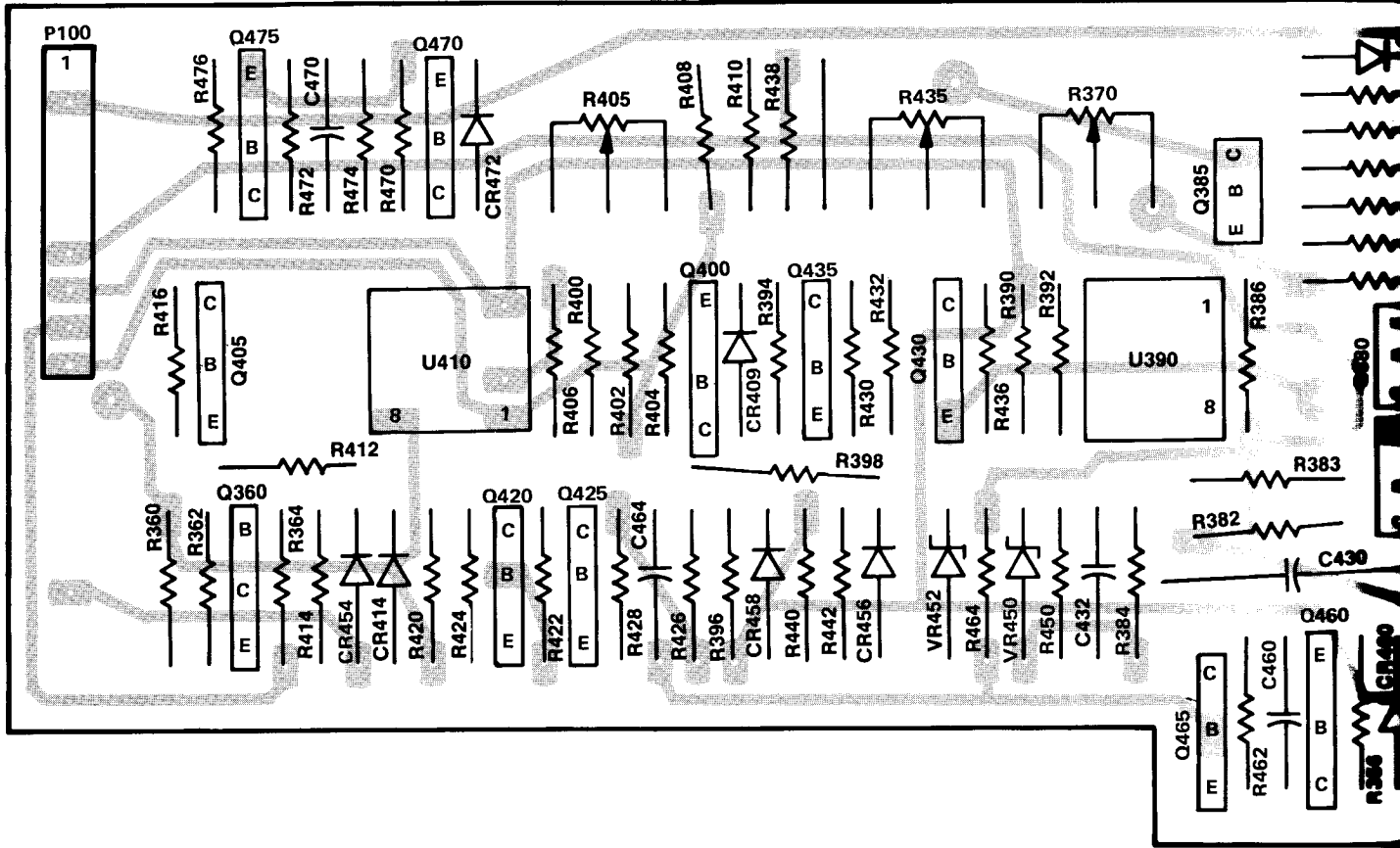

A350 Sweep Time Generator Bd.

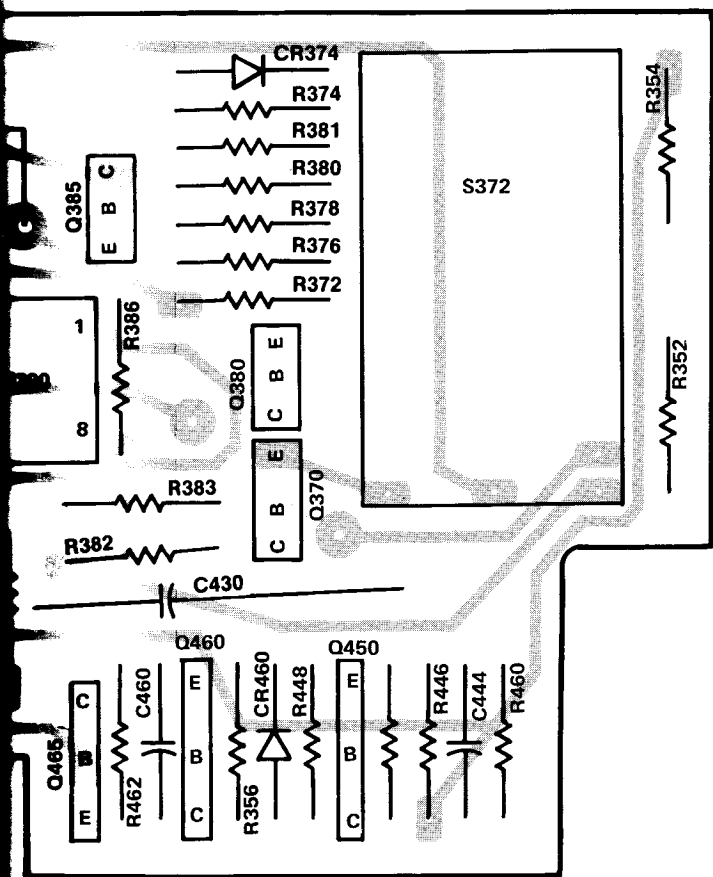

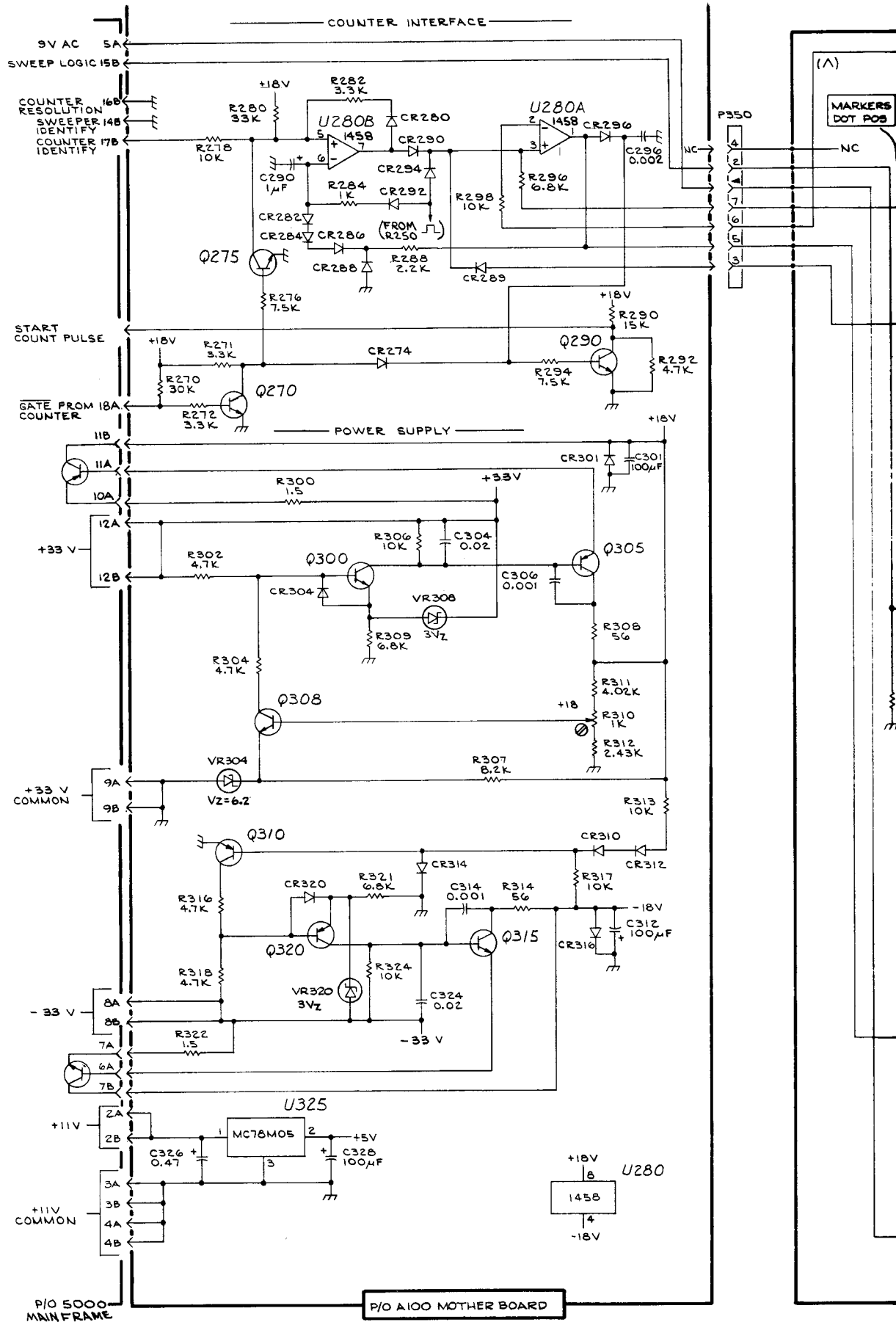

SW503

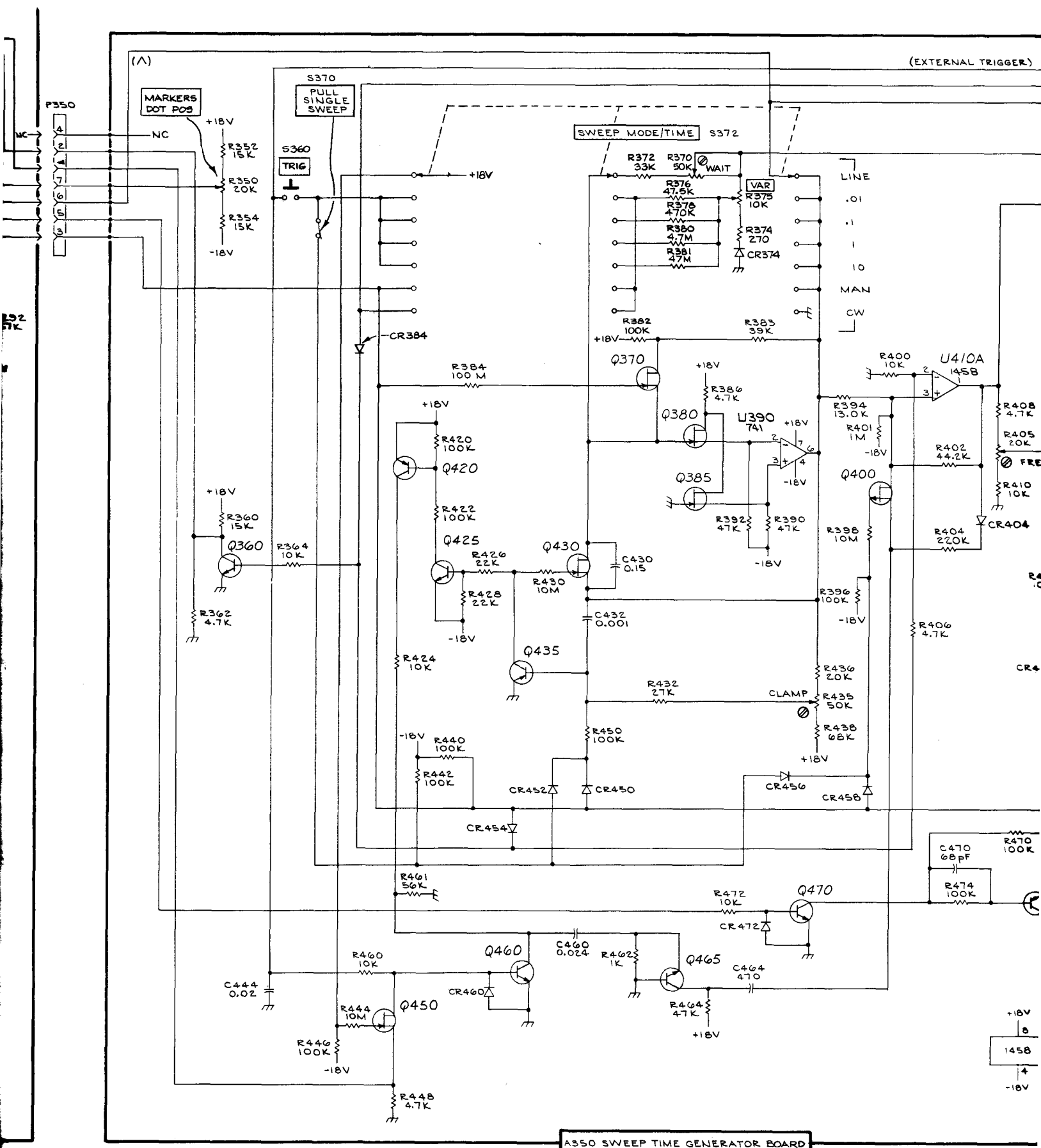

A350 SWEEP TIME GENERATOR BOARD

SWEEP TIME GENERATOR, POWER SUPPLY & COUNTER INTERFACE

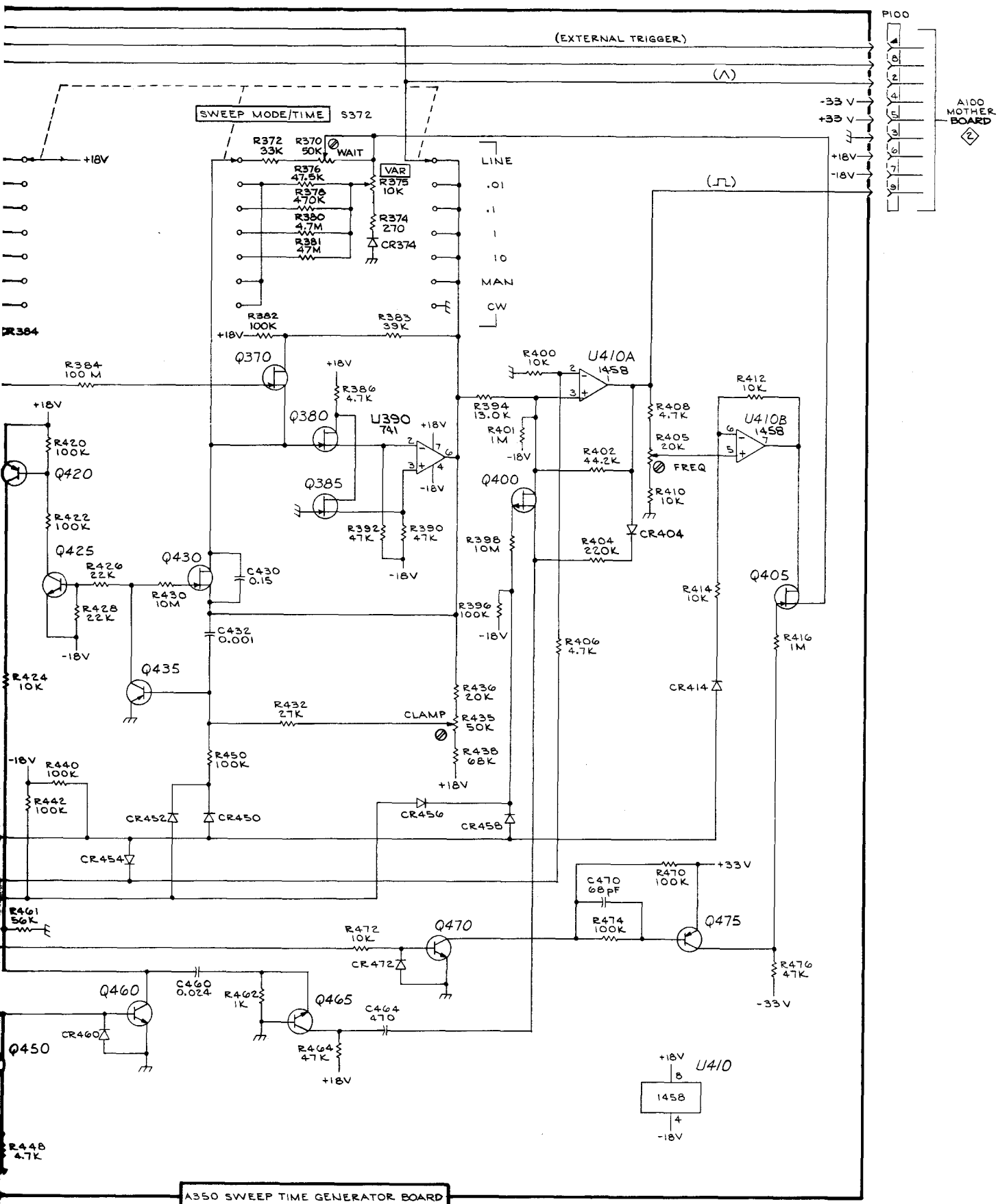

SWEEP TIME GENERATOR, POWER SUPPLY & COUNTER INTERFACE

SWEEP TIME GENERATOR, POWER SUPPLY & COUNTER INTERFACE

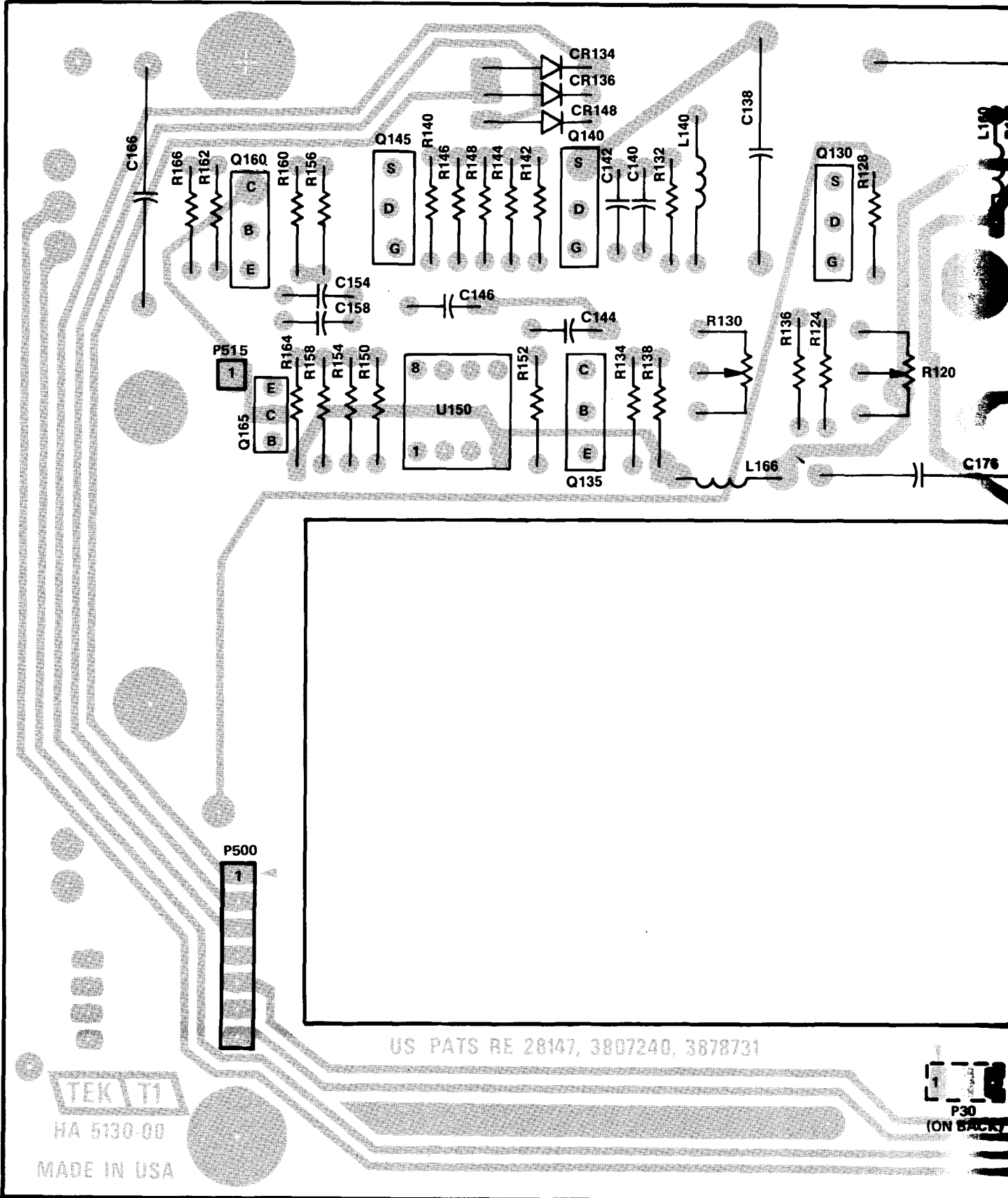

3

COMPONENT LOCATION FOR DIAGRAM

US PATS RE 28147, 3807240, 3878731

TEK T1

HA 5130-00

MADE IN USA



P30 (ON BACK)

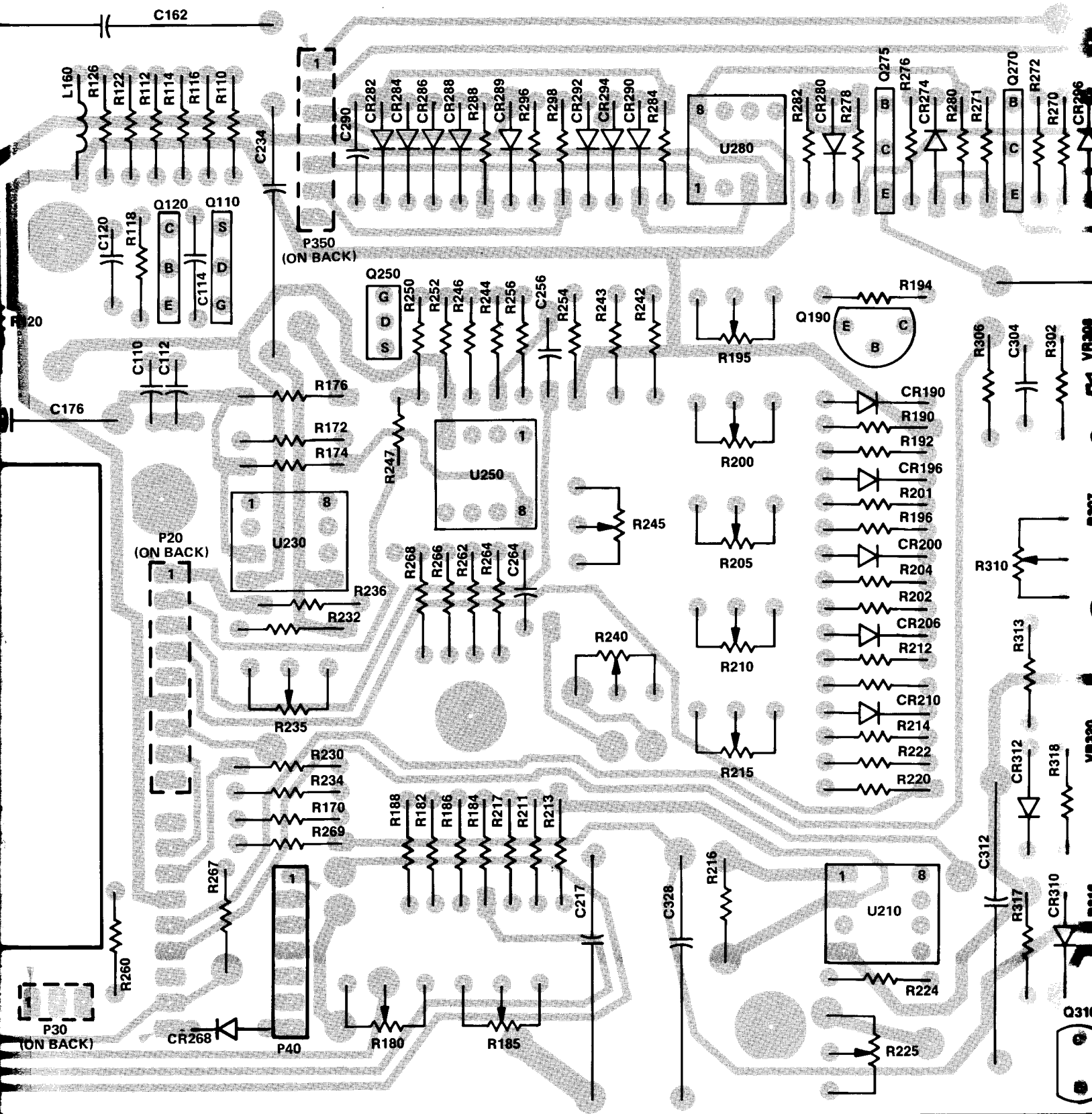

A100 Main Circuits Bd.

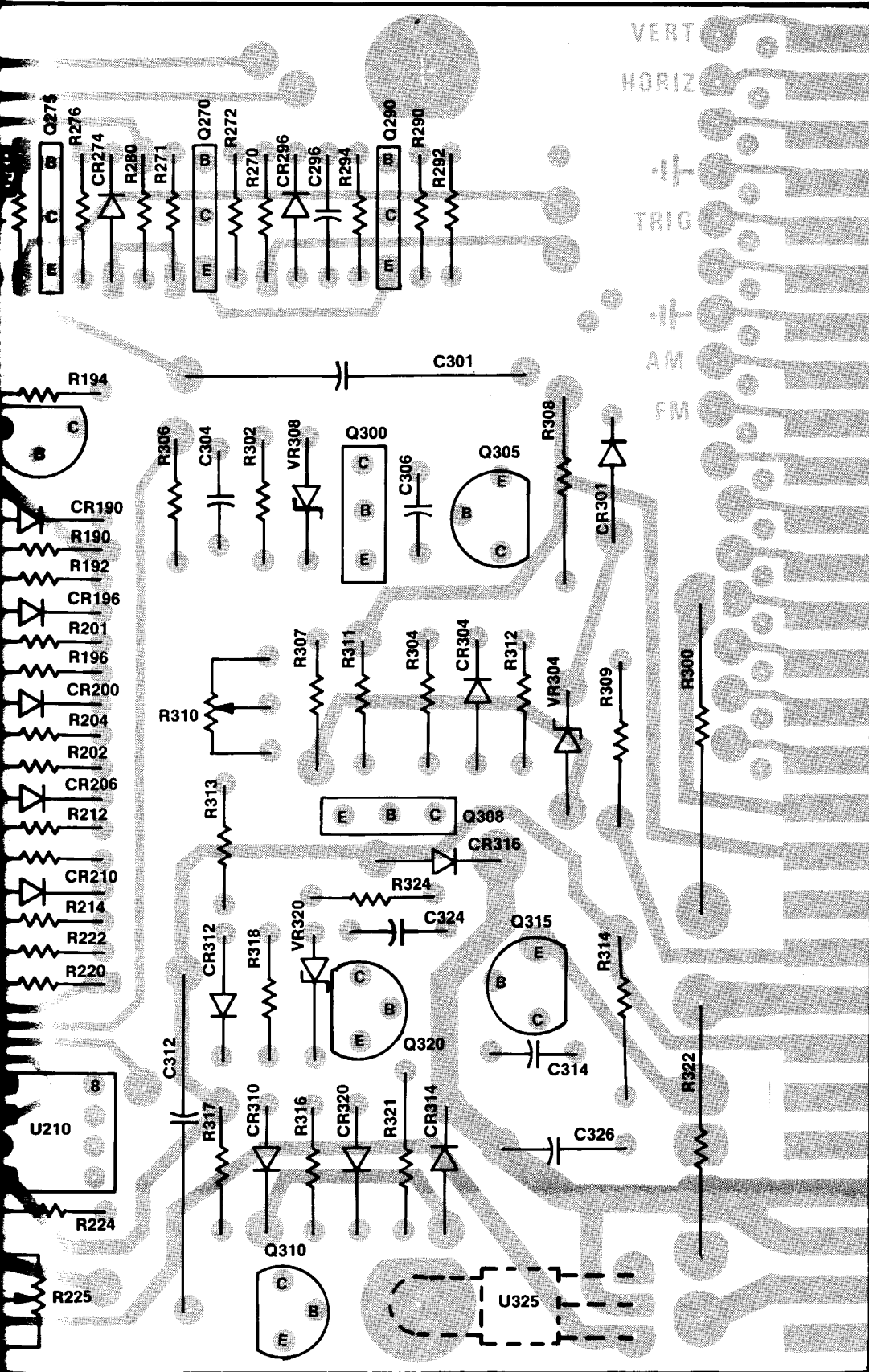

VERT

HORIZ

TRIG

AM

FM

U325

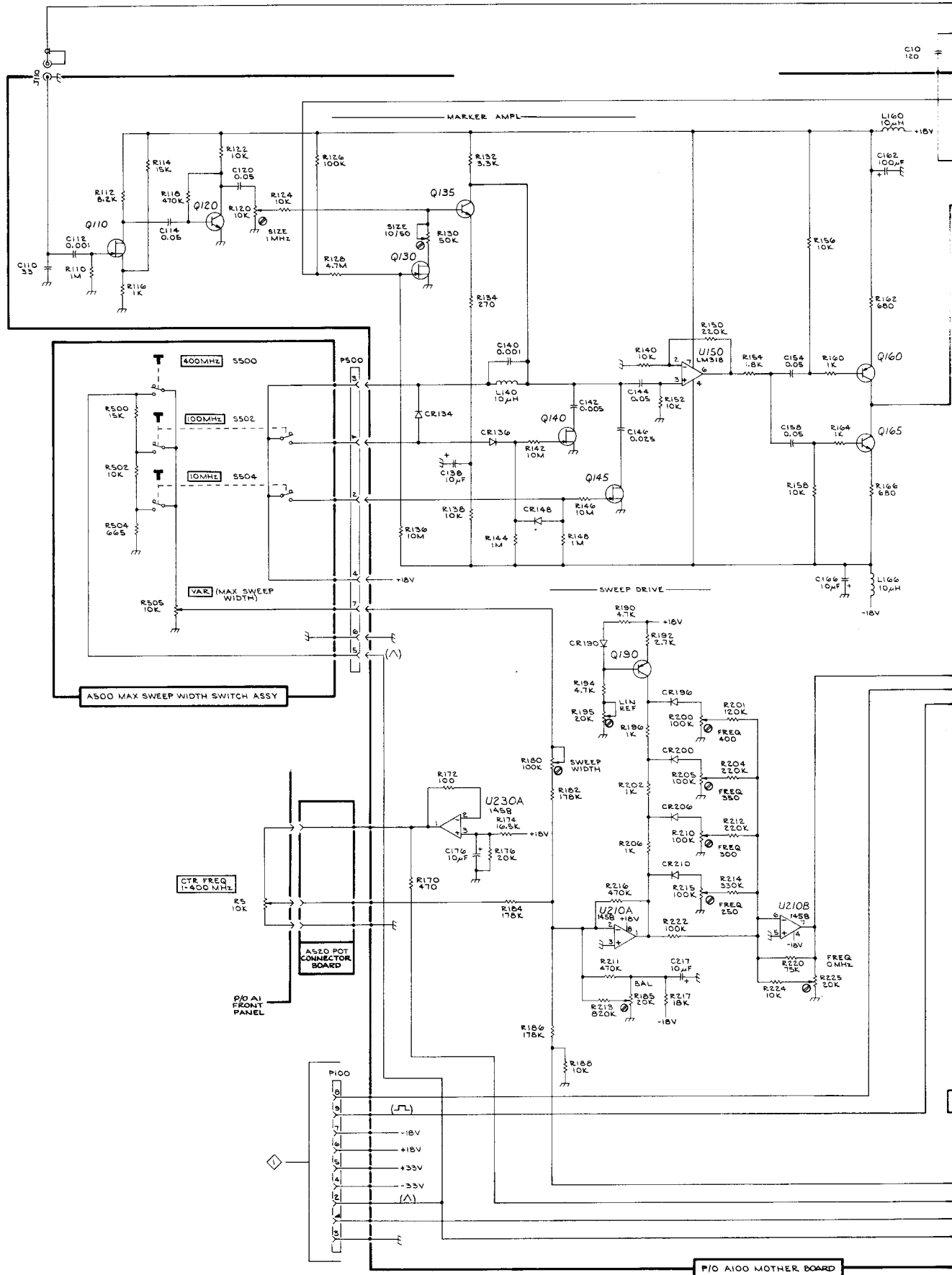

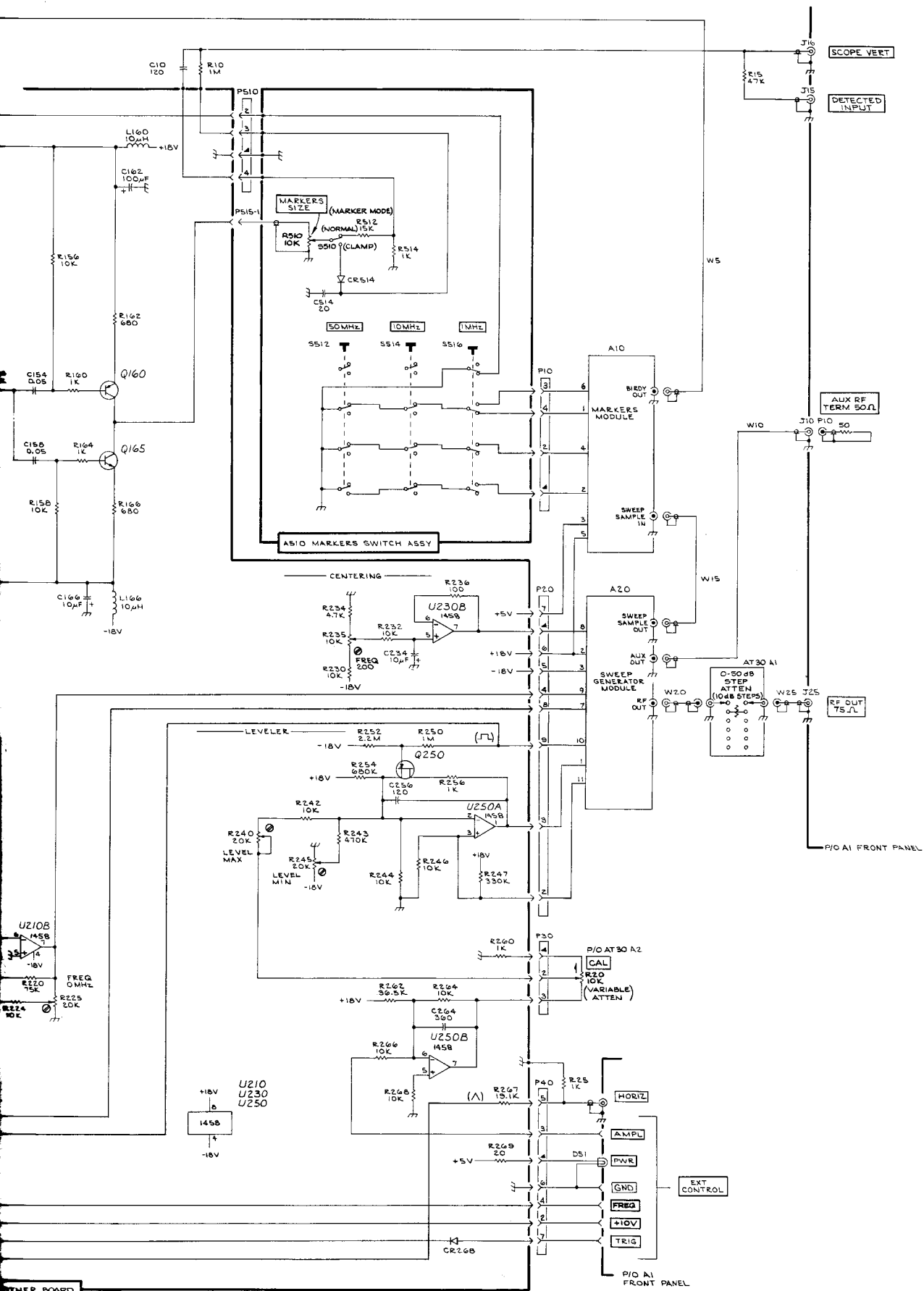

SWEEP & MARKER AMPLIFIERS

REPLACEABLE MECHANICAL PARTS

PARTS ORDERING INFORMATION

Replacement parts are available from or through your local Tektronix, Inc. Field Office or representative.

Changes to Tektronix instruments are sometimes made to accommodate improved components as they become available, and to give you the benefit of the latest circuit improvements developed in our engineering department. It is therefore important, when ordering parts, to include the following information in your order: Part number, instrument type or number, serial number, and modification number if applicable.

If a part you have ordered has been replaced with a new or improved part, your local Tektronix, Inc. Field Office or representative will contact you concerning any change in part number.

Change information, if any, is located at the rear of this manual.

SPECIAL NOTES AND SYMBOLS

X000 Part first added at this serial number
00X Part removed after this serial number

FIGURE AND INDEX NUMBERS

Items in this section are referenced by figure and index numbers to the illustrations.

INDENTATION SYSTEM

This mechanical parts list is indented to indicate item relationships. Following is an example of the indentation system used in the description column.

```

1 2 3 4 5           Name & Description
Assembly and/or Component
Attaching parts for Assembly and/or Component
-----
Detail Part of Assembly and/or Component
Attaching parts for Detail Part
-----
Parts of Detail Part
Attaching parts for Parts of Detail Part
-----

```

Attaching Parts always appear in the same indentation as the item it mounts, while the detail parts are indented to the right. Indented items are part of, and included with, the next higher indentation. The separation symbol - - - * - - - indicates the end of attaching parts.

Attaching parts must be purchased separately, unless otherwise specified.

ITEM NAME

In the Parts List, an Item Name is separated from the description by a colon (:). Because of space limitations, an Item Name may sometimes appear as incomplete. For further Item Name identification, the U.S. Federal Cataloging Handbook H6-1 can be utilized where possible.

ABBREVIATIONS

"	INCH	ELCTRN	ELECTRON	IN	INCH	SE	SINGLE END
#	NUMBER SIZE	ELEC	ELECTRICAL	INCAND	INCANDESCENT	SECT	SECTION
ACTR	ACTUATOR	ELCTLT	ELECTROLYTIC	INSUL	INSULATOR	SEMICOND	SEMICONDUCTOR
ADPTR	ADAPTER	ELEM	ELEMENT	INTL	INTERNAL	SHLD	SHIELD
ALIGN	ALIGNMENT	EPL	ELECTRICAL PARTS LIST	LPHLDR	LAMPHOLDER	SHLDR	SHOULDERED
AL	ALUMINUM	EQPT	EQUIPMENT	MACH	MACHINE	SKT	SOCKET
ASSEM	ASSEMBLED	EXT	EXTERNAL	MECH	MECHANICAL	SL	SLIDE
ASSY	ASSEMBLY	FIL	FILLISTER HEAD	MTG	MOUNTING	SLFLKG	SELF-LOCKING
ATTEN	ATTENUATOR	FLEX	FLEXIBLE	NIP	NIPPLE	SLVG	SLEEVING
AWG	AMERICAN WIRE GAGE	FLH	FLAT HEAD	NON WIRE	NOT WIRE WOUND	SPR	SPRING
BD	BOARD	FLTR	FILTER	OB	ORDER BY DESCRIPTION	SQ	SQUARE
BRKT	BRACKET	FR	FRAME or FRONT	OD	OUTSIDE DIAMETER	SST	STAINLESS STEEL
BRS	BRASS	FSTNR	FASTENER	OVH	OVAL HEAD	STL	STEEL
BRZ	BRONZE	FT	FOOT	PH BRZ	PHOSPHOR BRONZE	SW	SWITCH
BSHG	BUSHING	FXD	FIXED	PL	PLAIN or PLATE	T	TUBE
CAB	CABINET	GSKT	GASKET	PLSTC	PLASTIC	TERM	TERMINAL
CAP	CAPACITOR	HDL	HANDLE	PN	PART NUMBER	THD	THREAD
CER	CERAMIC	HEX	HEXAGON	PNH	PAN HEAD	THK	THICK
CHAS	CHASSIS	HEX HD	HEXAGONAL HEAD	PWR	POWER	TNSN	TENSION
CKT	CIRCUIT	HEX SOC	HEXAGONAL SOCKET	RCPT	RECEPTACLE	TPG	TAPPING
COMP	COMPOSITION	HLCPS	HELICAL COMPRESSION	RES	RESISTOR	TRH	TRUSS HEAD
CONN	CONNECTOR	HLEXT	HELICAL EXTENSION	RGD	RIGID	V	VOLTAGE
COV	COVER	HV	HIGH VOLTAGE	RLF	RELIEF	VAR	VARIABLE
CPLG	COUPLING	IC	INTEGRATED CIRCUIT	RTNR	RETAINER	W/	WITH
CRT	CATHODE RAY TUBE	ID	INSIDE DIAMETER	SCH	SOCKET HEAD	WSHR	WASHER
DEG	DEGREE	IDENT	IDENTIFICATION	SCOPE	OSCILLOSCOPE	XFMR	TRANSFORMER
DWR	DRAWER	IMPLR	IMPELLER	SCR	SCREW	XSTR	TRANSISTOR

CROSS INDEX—MFR. CODE NUMBER TO MANUFACTURER

Mfr. Code	Manufacturer	Address	City, State, Zip
00779	AMP, INC.	P O BOX 3608	HARRISBURG, PA 17105
	NO ENTRY FOR 05009		
05091	TRI-ORDINATE CORPORATION	343 SNYDER AVENUE	BERKELEY HEIGHTS, NJ 07922
08261	SPECTRA-STRIP CORP.	7100 LAMPSON AVE.	GARDEN GROVE, CA 92642
12327	FREEWAY CORPORATION	9301 ALLEN DRIVE	CLEVELAND, OH 44125
22526	BERG ELECTRONICS, INC.	YOUK EXPRESSWAY	NEW CUMBERLAND, PA 17070
32997	BOURNS, INC., TRIMPOT PRODUCTS DIV.	1200 COLUMBIA AVE.	RIVERSIDE, CA 92507
34280	WAVETEK INDIANA, INC.	PO BOX 190, 66N FIRST AVENUE	BEECH GROVE, IN 46107
45722	USM CORP., PARKER-KALON FASTENER DIV.		CAMPBELLSVILLE, KY 42718
71159	BRISTOL SOCKET SCREW, DIV. OF AMERICAN CHAIN AND CABLE CO., INC.	P O BOX 2244, 40 BRISTOL ST.	WATERBURY, CT 06720
71279	CAMBRIDGE THERMIONIC CORP.	445 CONCORD AVE.	CAMBRIDGE, MA 02138
73743	FISCHER SPECIAL MFG. CO.	446 MORGAN ST.	CINCINNATI, OH 45206
73803	TEXAS INSTRUMENTS, INC., METALLURGICAL MATERIALS DIV.	34 FOREST STREET	ATTLEBORO, MA 02703
74445	HOLO-KROME CO.	31 BROOK ST. WEST	HARTFORD, CT 06110
78189	ILLINOIS TOOL WORKS, INC. SHAKEPROOF DIVISION	ST. CHARLES ROAD	ELGIN, IL 60120
80009	TEKTRONIX, INC.	P O BOX 500	BEAVERTON, OR 97077
81073	GRAYHILL, INC.	561 HILLGROVE AVE., PO BOX 373	LA GRANGE, IL 60525
83385	CENTRAL SCREW CO.	2530 CRESCENT DR.	BROADVIEW, IL 60153
91836	KINGS ELECTRONICS CO., INC.	40 MARBLEDALE ROAD	TUCKAHOE, NY 10707

Fig. & Index No.	Tektronix Part No.	Serial/Model No.		Qty	1 2 3 4 5	Name & Description	Mfr Code	Mfr Part Number
		Eff	Dscont					
1-1	337-1399-00			2		SHLD,ELECTRICAL:SIDE	80009	337-1399-00
-2	366-1031-02	B010100	B010299	1		KNOB:RED-VAR	80009	366-1031-02
	366-1031-06	B010300		1		KNOB:GRAY--VAR	80009	366-1031-06
	213-0153-00			1		. SETSCREW:5-40 X 0.125 INCH,HEX SOC STL	74445	OBD
-3	366-1023-01	B010100	B010299	2		KNOB:GRAY	80009	366-1023-01
	366-1023-07	B010300		2		KNOB:GRAY,0.127 ID,0.392 OD,0.466	80009	366-1023-07
	-----			-		. EACH KNOB INCLUDES:		
	213-0246-00			1		. SETSCREW:5-40 X 0.093 INCH L,HEX SOC	71159	OBD
-4	366-1023-02	B010100	B010299	1		KNOB:GRAY--VAR	80009	366-1023-02
	366-1023-09	B010300		1		KNOB:GRAY--VAR	80009	366-1023-09
	213-0246-00			1		. SETSCREW:5-40 X 0.093 INCH L,HEX SOC	71159	OBD
-5	366-1269-00			1		KNOB:GRAY,1-500	80009	366-1269-00
-6	366-1031-03	B010100	B010299	1		KNOB:RED--CAL	80009	366-1031-03
	366-1464-02	B010300		1		KNOB:GRAY--CAL	80009	366-1464-02
	213-0153-00			1		. SETSCREW:5-40 X 0.125 INCH,HEX SOC STL	74445	OBD
-7	366-1165-00	B010100	B010299	2		KNOB:GRAY	80009	366-1165-00
	366-1165-01	B010300		2		KNOB:GRAY,0.252 ID,0.706 OD,0.65 H	80009	366-1165-01
	-----			-		. EACH KNOB INCLUDES:		
	213-0153-00			2		. SETSCREW:5-40 X 0.125 INCH,HEX SOC STL	74445	OBD
-8	131-0818-00			2		CONNECTOR,RCPT,:BNC,FEMALE	91836	KC19-153BNC
-9	131-0955-00			3		CONNECTOR,RCPT,:BNC,FEMALE,W/HARDWARE	05091	31-279
-10	366-1520-02			1		KNOB:GRAY	80009	366-1520-02
						(ATTACHING PARTS)		
-11	214-1840-00			1		PIN,KNOB SECRG:0.094 OD X 0.120 INCH LONG	80009	214-1840-00
						-----*		
-12	136-0387-00			5		JACK,TIP:GRAY	71279	4352-1-0318
-13	348-0067-00			1		GROMMET,PLASTIC:0.312 INCH DIA	80009	348-0067-00
-14	426-1072-00			6		FRAME,PUSH BTN:PLASTIC	80009	426-1072-00
-15	118-0056-00			1		MODULE,SWEEP:75 OHM	80009	118-0056-00
	118-0057-00			1		MODULE,SWEEP:50 OHM	80009	118-0057-00
						(ATTACHING PARTS)		
-16	211-0507-00			1		SCREW,MACHINE:6-32 X 0.312 INCH,PNH STL	83385	OBD
-17	211-0007-00			1		SCREW,MACHINE:4-40 X 0.188 INCH,PNH STL	83385	OBD
						-----*		
-18	118-0058-00			1		MODULE,MARKER:	80009	118-0058-00
						(ATTACHING PARTS)		
-19	211-0507-00			1		SCREW,MACHINE:6-32 X 0.312 INCH,PNH STL	83385	OBD
-20	211-0007-00			1		SCREW,MACHINE:4-40 X 0.188 INCH,PNH STL	83385	OBD
						-----*		
-21	118-0051-00			1		BRACKET,MODULE:	80009	118-0051-00
						(ATTACHING PARTS)		
-22	211-0559-00			2		SCREW,MACHINE:6-32 X 0.375"100 DEG,FLH STL	83385	OBD
-23	361-0122-00			2		SPACER,SLEEVE:0.125 L X 0.12 ID BRS	80009	361-0122-00
						-----*		
-24	118-0068-00			1		RESISTOR,VAR:10K OHM,5.5MM SHAFT	80009	118-0068-00
						(ATTACHING PARTS)		
-25	210-0583-00			1		NUT,PLAIN,HEX.:0.25-32 X 0.312 INCH,BRS	73743	2X20224-402
-26	210-0046-00			1		WASHER,LOCK:INTL,0.26 ID X 0.40" OD,STL	78189	1214-05-00-0541C
						-----*		
-27	366-1559-00			6		PUSH BUTTON:GRAY	80009	366-1559-00
-28	118-0052-00			1		CKT CARD ASSY:ATTEN BRKT AND MARKER	80009	118-0052-00
						(ATTACHING PARTS)		
-29	211-0007-00			2		SCREW,MACHINE:4-40 X 0.188 INCH,PNH STL	83385	OBD
-30	210-0802-00			2		WASHER,FLAT:0.15 ID X 0.312 INCH OD	12327	OBD
						-----*		
	-----			-		. CKT BOARD ASSY INCLUDES:		
-31	131-1426-00			1		. CONTACT SET,ELE:R ANGLE,0.250L,STRIP OF 36	22526	65524-436
-32	-----			1		RESISTOR,VAR:10K OHM	34280	RP146-310
						(ATTACHING PARTS)		
-33	211-0008-00			2		SCREW,MACHINE:4-40 X 0.25 INCH,PNH STL	83385	OBD
						-----*		
-34	118-0054-00			1		ATTENUATOR,VAR:75 OHM	34280	7550-2

Replaceable Mechanical Parts—SW 503

Fig. & Index No.	Tektronix Part No.	Serial/Model No. Eff	Dscont	Qty	1 2 3 4 5	Name & Description	Mfr Code	Mfr Part Number
1-	118-0055-00			1		ATTENUATOR,VAR:50 OHM (ATTACHING PARTS)	34280	A600-013-OZ
-35	212-0004-00			2		SCREW,MACHINE:8-32 X 0.312 INCH,PNH STL - - - * - - -	83385	OBD
-36	118-0066-00			1		BRACKET,ATTEN:L-SHAPED (ATTACHING PARTS)	80009	118-0066-00
-37	211-0541-00			2		SCREW,MACHINE:6-32 X 0.25"100 DEG,FLH STL - - - * - - -	83385	OBD
-38	118-0069-00			1		RESISTOR,VAR:10K OHM,2MM SHAFT (ATTACHING PARTS)	80009	118-0069-00
-39	210-0583-00			1		NUT,PLAIN,HEX.:0.25-32 X 0.312 INCH,BRS	73743	2X20224-402
-40	210-0046-00			1		WASHER,LOCK:INTL,0.26 ID X 0.40" OD,STL - - - * - - -	78189	1214-05-00-0541C
-41	260-0735-00			1		SWITCH,PUSH:SPST	81073	39-1
-42	-----			1		RESISTOR,VAR:10K OHM (ATTACHING PARTS)	34280	RP145-310
-43	210-0406-00			2		NUT,PLAIN,HEX.:4-40 X 0.188 INCH,BRS	73743	2X12161-402
-44	210-0004-00			2		WASHER,LOCK:INTL,0.12 ID X 0.26"OD,STL	78189	1204-00-00-0541C
-45	211-0014-00			2		SCREW,MACHINE:4-40 X 0.50 INCH,PNH STL - - - * - - -	83385	OBD
-46	118-0053-00			1		DOT MKR SWP AS: (ATTACHING PARTS)	80009	118-0053-00
-47	210-0413-00			1		NUT,PLAIN,HEX.:0.375-32 X 0.50 INCH,STL	73743	3145-402
-48	211-0008-00			1		SCREW,MACHINE:4-40 X 0.25 INCH,PNH STL - - - * - - -	83385	OBD
-49	136-0514-00			-		. DOT MARKER SWP ASSY INCLUDES:		
-50	131-1426-00			2		. SOCKET,PLUG IN:MICROCIRCUIT,8 CONTACT	73803	C9308-02
-51	333-2187-00	B010100 B010299		1		. CONTACT SET,ELE:R ANGLE,0.250L,STRIP OF 36	22526	65524-436
	333-2187-01	B010300		1		PANEL,FRONT:	80009	333-2187-00
	333-2186-00	B010100 B010299		1		PANL,FRONT:	80009	333-2187-01
	333-2186-01	B010300		1		PANEL FRONT:OPTION 1 ONLY	80009	333-2186-00
-52	214-1513-01			1		PANEL,FRONT:OPTION 1 ONLY	80009	333-2186-01
				1		LCH,PLUG-IN RET: (ATTACHING PARTS)	80009	214-1513-01
-53	213-0254-00			1		SCR,TPG,THD CTG:2-32 X 0.250,100 DEG,FLH - - - * - - -	45722	OBD
-54	200-0935-00			1		BASE,LAMPHOLDER:0.29 OD X 0.19 CASE	80009	200-0935-00
-55	378-0602-00			1		LENS,LIGHT:GREEN	80009	378-0602-00
-56	352-0157-00			1		LAMPHOLDER:WHITE PLASTIC	80009	352-0157-00
-57	386-3583-00	B010100 B010299		1		SUBPANEL,FRONT:	80009	386-3583-00
	386-3583-01	B010300		1		SUBPANEL,FRONT: (ATTACHING PARTS)	80009	386-3583-01
-58	213-0229-00			4		SCR,TPG,THD FOR:6-20 X0.375"100 DEG,FLH STL - - - * - - -	83385	OBD
-59	337-2352-00	B010100 B010299		1		SHIELD,ELEC:FRONT PANEL	80009	337-2352-00
	337-2352-01	B010300		1		SHIELD,ELEC:FRONT PANEL	80009	337-2352-01
-60	388-1704-00			1		CIRCUIT BOARD:RESISTANCE SOCKET	80009	388-1704-00
-61	136-0261-00			3		SOCKET,PIN TERM:FOR 0.22 INCH PIN	00779	1-331677-6
-62	118-0084-00			1		RES.,VAR,WW:10K OHM,5%,1.5W (ATTACHING PARTS)	32997	36108-534-103
-63	210-0413-00			1		NUT,PLAIN,HEX.:0.375-32 X 0.50 INCH,STL	73743	3145-402
-64	210-0021-00			1		WASHER,LOCK:INTL,0.476 ID X 0.60"OD STL	78189	1222-01-00-0541C
-65	220-0459-00			1		NUT,PLAIN,DODEC:	73743	2XX-64066-101
-66	210-0047-00			1		WASHER,LOCK:0.88 ID X 1.110 OD - - - * - - -	78189	1234-04-00-0541C
-67	118-0067-00			1		RESISTOR,VAR:10K OHM,14.5MM SHAFT (ATTACHING PARTS)	80009	118-0067-00
-68	210-0583-00			1		NUT,PLAIN,HEX.:0.25-32 X 0.312 INCH,BRS	73743	2X20224-402
-69	210-0046-00			1		WASHER,LOCK:INTL,0.26 ID X 0.40" OD,STL - - - * - - -	78189	1214-05-00-0541C
-70	118-0062-00			1		CKT BOARD ASSY:SWEET WIDTH (ATTACHING PARTS)	80009	118-0062-00
-71	211-0008-00			2		SCREW,MACHINE:4-40 X 0.25 INCH,PNH STL - - - * - - -	83385	OBD

Fig. & Index No.	Tektronix Part No.	Serial/Model No. Eff Dscont	Qty	1 2 3 4 5	Name & Description	Mfr Code	Mfr Part Number
1-72	118-0059-00		1		CKT BOARD ASSY:MAIN (ATTACHING PARTS)	80009	118-0059-00
-73	211-0503-00		4		SCREW,MACHINE:6-32 X 0.188 INCH,PNH STL	83385	OBD
	-----		-		. CKT BOARD ASSY INCLUDES:		
-74	131-0608-00		4		. CONTACT,ELEC:0.365 L X 0.25 PH BRZ GOLD PL	22526	47357
-75	131-1426-00		1		. CONTACT SET,ELE:R ANGLE,0.250L,STRIP OF 36	22526	65524-436
-76	129-0320-00		2		. POST,ELEC-MECH:0.187 OD X 0.15 INCH LONG	80009	129-0120-00
-77	131-1505-00		1		. CONN,RCPT,ELEC:	05009	0500430149220
-78	136-0514-00		5		. SOCKET,PLUG IN:MICROCIRCUIT,8 CONTACT	73803	C9308-02
-79	118-0063-00		1		FR SECT,PLUG-IN:BOTTOM	34280	C900-232 BOTTOM
-80	214-1061-00		1		SPRING,GROUND:FLAT	80009	214-1061-00
-81	118-0064-00		1		FR SECT,PLUG-IN:TOP	34280	C900-232 TOP
-82	118-0060-00		1		WIRE SET,ELEC:50 OHM	80009	118-0060-00
	118-0061-00		1		WIRE SET,ELEC:75 OHM	80009	118-0061-00
-83	175-0825-00		FT		WIRE,ELECTRICAL:2 WIRE RIBBON	08261	OBD
-84	175-0826-00		FT		WIRE,ELECTRICAL:3 WIRE RIBBON	80009	175-0826-00
-85	175-0827-00		FT		WIRE,ELECTRICAL:4 WIRE RIBBON	80009	175-0827-00
-86	175-0829-00		FT		WIRE,ELECTRICAL:6 WIRE RIBBON	08261	OBD
-87	175-0830-00		FT		WIRE,ELECTRICAL:7 WIRE RIBBON	08261	OBD
-88	175-0831-00		FT		WIRE,ELECTRICAL:8 WIRE RIBBON	08261	OBD
-89	352-0171-00		1		CONN BODY,PL,EL:1 WIRE BLACK	80009	352-0171-00
-90	131-0707-00		51		CONTACT,ELEC:0.48" L,22-26 AWG WIRE	22526	5999-00-396-6331
-91	352-0161-00		1		CONN BODY,PL,EL:3 WIRE BLACK	80009	352-0161-00
-92	352-0162-00		2		CONN BODY,PL,EL:4 WIRE BLACK	80009	352-0162-00
-93	352-0165-00		3		CONN BODY,PL,EL:7 WIRE BLACK	80009	352-0165-00
-94	352-0167-00		2		CONN BODY,PL,EL:9 WIRE BLACK	80009	352-0167-00

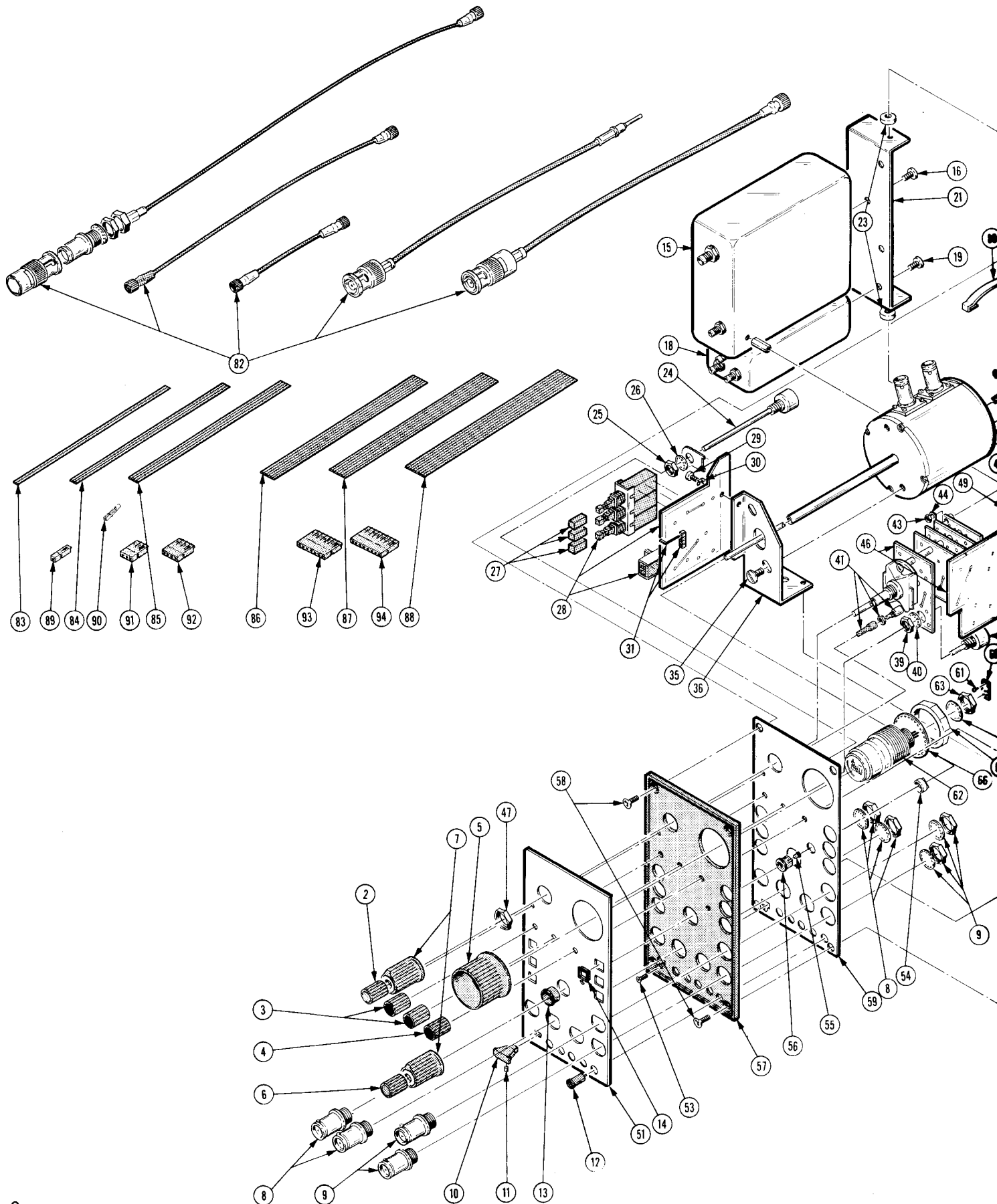

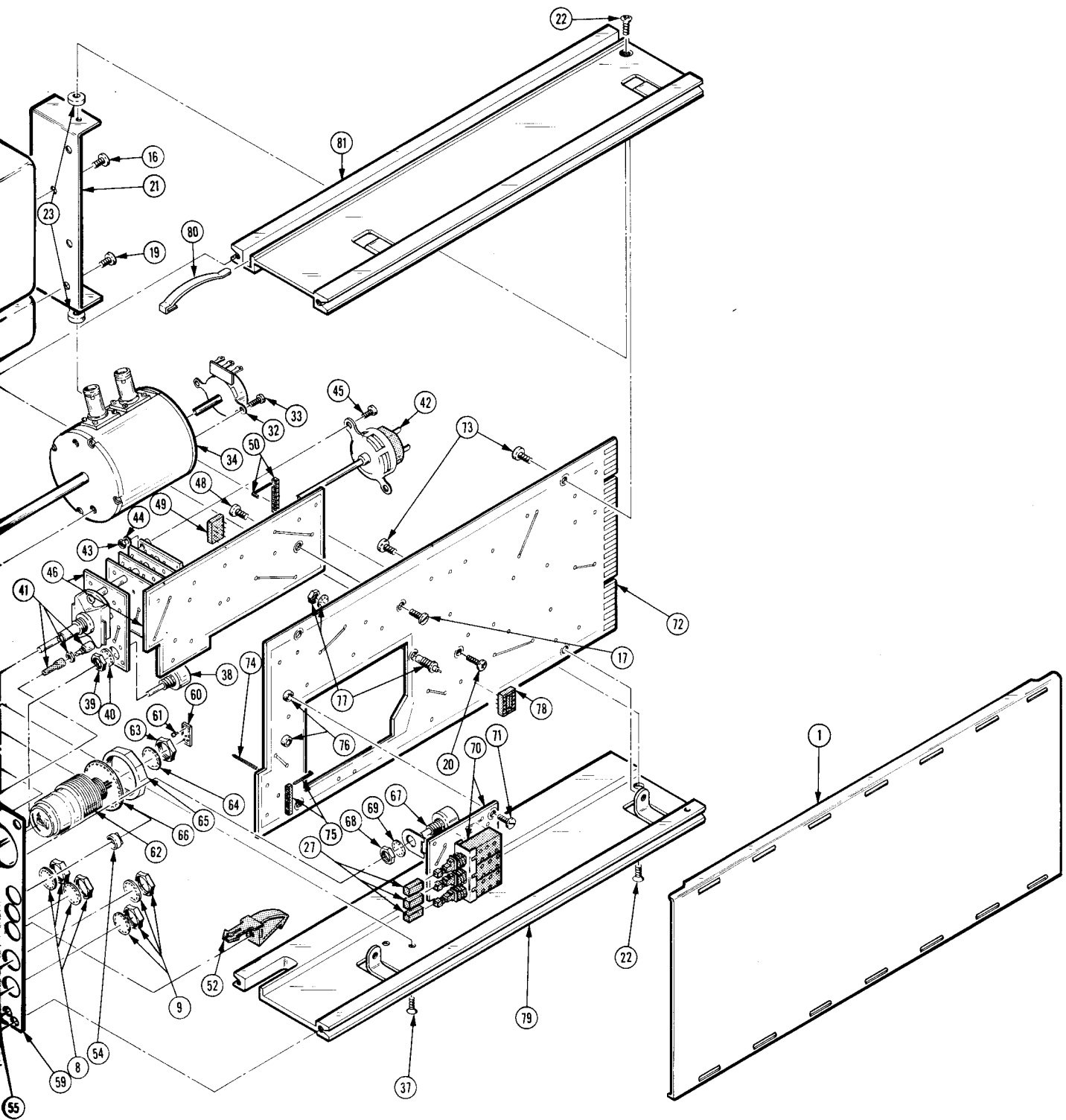

SW 503 RF SWEEP GENERATOR

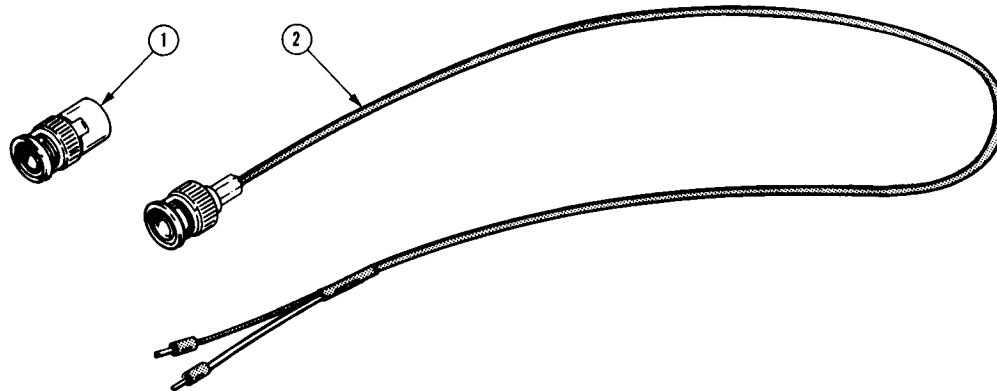

Fig. & Index No.	Tektronix Part No.	Serial/Model No.		Qty						Name & Description	Mfr Code	Mfr Part Number
		Eff	Dscont		1	2	3	4	5			
-1	118-0065-00			1						TERMINATION, GEN: 50 OHM	80009	118-0065-00
-2	175-1178-00			1						CABLE, SP, ELEC: RF, 20 INCH LONG	80009	175-1178-00
	070-2051-00			1						MANUAL, TECH: INSTRUCTION	80009	070-2051-00
OPTIONAL ACCESSORIES												
	118-0070-00			1						DETECTOR, RF: 50 OHM	80009	118-0070-00
	118-0071-00			1						DETECTOR, RF: 75 OHM (OPTION 1 ONLY)	80009	118-0071-00

MANUAL CHANGE INFORMATION

At Tektronix, we continually strive to keep up with latest electronic developments by adding circuit and component improvements to our instruments as soon as they are developed and tested.

Sometimes, due to printing and shipping requirements, we can't get these changes immediately into printed manuals. Hence, your manual may contain new change information on following pages.

A single change may affect several sections. Since the change information sheets are carried in the manual until all changes are permanently entered, some duplication may occur. If no such change pages appear following this page, your manual is correct as printed.

SERVICE NOTE

Because of the universal parts procurement problem, some electrical parts in your instrument may be different from those described in the Replaceable Electrical Parts List. The parts used will in no way alter or compromise the performance or reliability of this instrument. They are installed when necessary to ensure prompt delivery to the customer. Order replacement parts from the Replaceable Electrical Parts List.

CALIBRATION TEST EQUIPMENT REPLACEMENT

Calibration Test Equipment Chart

This chart compares TM 500 product performance to that of older Tektronix equipment. Only those characteristics where significant specification differences occur, are listed. In some cases the new instrument may not be a total functional replacement. Additional support instrumentation may be needed or a change in calibration procedure may be necessary.

Comparison of Main Characteristics

DM 501 replaces 7D13		
PG 501 replaces 107	PG 501 - Risetime less than 3.5 ns into 50 Ω .	107 - Risetime less than 3.0 ns into 50 Ω .
108	PG 501 - 5 V output pulse; 3.5 ns Risetime.	108 - 10 V output pulse; 1 ns Risetime.
111	PG 501 - Risetime less than 3.5 ns; 8 ns Pretrigger pulse delay.	111 - Risetime 0.5 ns; 30 to 250 ns Pretrigger Pulse delay.
114	PG 501 - ± 5 V output.	114 - ± 10 V output. Short proof output.
115	PG 501 - Does not have Paired, Burst, Gated, or Delayed pulse mode; ± 5 V dc Offset. Has ± 5 V output.	115 - Paired, Burst, Gated, and Delayed pulse mode; ± 10 V output. Short-proof output.
PG 502 replaces 107		
108	PG 502 - 5 V output	108 - 10 V output.
111	PG 502 - Risetime less than 1 ns; 10 ns Pretrigger pulse delay.	111 - Risetime 0.5 ns; 30 to 250 ns Pretrigger pulse delay.
114	PG 502 - ± 5 V output	114 - ± 10 V output. Short proof output.
115	PG 502 - Does not have Paired, Burst, Gated, Delayed & Undelayed pulse mode; Has ± 5 V output.	115 - Paired, Burst, Gated, Delayed & Undelayed pulse mode; ± 10 V output. Short-proof output.
2101	PG 502 - Does not have Paired or Delayed pulse. Has ± 5 V output.	2101 - Paired and Delayed pulse; 10 V output.
PG 506 replaces 106	PG 506 - Positive-going trigger output signal at least 1 V; High Amplitude output, 60 V.	106 - Positive and Negative-going trigger output signal, 50 ns and 1 V; High Amplitude output, 100 V.
067-0502-01	PG 506 - Does not have chopped feature.	0502-01 - Comparator output can be alternately chopped to a reference voltage.
SG 503 replaces 190, 190A, 190B	SG 503 - Amplitude range 5 mV to 5.5 V p-p.	190B - Amplitude range 40 mV to 10 V p-p.
191	SG 503 - Frequency range 250 kHz to 250 MHz.	191 - Frequency range 350 kHz to 100 MHz.
067-0532-01	SG 503 - Frequency range 250 kHz to 250 MHz.	0532-01 - Frequency range 65 MHz to 500 MHz.
TG 501 replaces 180, 180A	TG 501 - Marker outputs, 5 sec to 1 ns. Sinewave available at 5, 2, and 1 ns. Trigger output - slaved to marker output from 5 sec through 100 ns. One time-mark can be generated at a time.	180A - Marker outputs, 5 sec to 1 μ s. Sinewave available at 20, 10, and 2 ns. Trigger pulses 1, 10, 100 Hz; 1, 10, and 100 kHz. Multiple time-marks can be generated simultaneously.
181	TG 501 - Marker outputs, 5 sec to 1 ns. Sinewave available at 5, 2, and 1 ns.	181 - Marker outputs, 1, 10, 100, 1000, and 10,000 μ s, plus 10 ns sinewave.
184	TG 501 - Marker outputs, 5 sec to 1 ns. Sinewave available at 5, 2, and 1 ns. Trigger output - slaved to marker output from 5 sec through 100 ns. One time-mark can be generated at a time.	184 - Marker outputs, 5 sec to 2 ns. Sinewave available at 50, 20, 10, 5, and 2 ns. Separate trigger pulses of 1 and .1 sec; 10, 1, and .1 ms; 10 and 1 μ s. Marker amplifier provides positive or negative time marks of 25 V min. Marker intervals of 1 and .1 sec; 10, 1, and .1 ms; 10 and 1 μ s.
2901	TG 501 - Marker outputs, 5 sec to 1 ns. Sinewave available at 5, 2, and 1 ns. Trigger output - slaved to marker output from 5 sec through 100 ns. One time-mark can be generated at a time.	2901 - Marker outputs, 5 sec to 0.1 μ s. Sinewave available to 50, 10, and 5 ns. Separate trigger pulses, from 5 sec to 0.1 μ s. Multiple time-marks can be generated simultaneously.

NOTE: All TM 500 generator outputs are short-proof. All TM 500 plug-in instruments require TM 500-Series Power Module.



TEKTRONIX®
*committed to
 technical excellence*

MANUAL CHANGE INFORMATION

PRODUCT SW503
070-2051-00

CHANGE REFERENCE M31733
 DATE 5-17-77

CHANGE:	DESCRIPTION
---------	-------------

EFF SN B010368

ELECTRICAL PARTS LIST AND SCHEMATIC CHANGES

CHANGE TO:

- | | | |
|-------|-------------|---------------------------------------|
| CR374 | 152-0008-00 | SEMICOND DEVICE:SILICON,60V,60MA,T12G |
| R374 | 315-0471-00 | RES.,FXD,CMPSN:470 OHM,5%,0.25W |

The above parts are located on the SWEEP TIME GENERATOR circuit board and are shown on diagram 2 SWEEP TIME GENERATOR, POWER SUPPLY & COUNTER INTERFACE.



TEKTRONIX®
committed to
technical excellence

MANUAL CHANGE INFORMATION

PRODUCT SW503
070-2051-00

CHANGE REFERENCE M31789
DATE 6-2-77

CHANGE:	DESCRIPTION
---------	-------------

EFF SN B020460

ELECTRICAL PARTS LIST AND SCHEMATIC CHANGES

CHANGE TO:

R230 315-0472-03 RES., FXD, CMPSN:4.7K OHM, 5%, 0.25W

R234 315-0103-00 RES., FXD, CMPSN:10K OHM, 5%, 0.25W

R230 and R234 are located on the MOTHER board and are shown on diagram 3
SWEEP & MARKER AMPLIFIERS.